



**TOWN OF NEWBURGH  
PLANNING BOARD  
TECHNICAL REVIEW COMMENTS**

**PROJECT NAME:** O'DONNELL SITE PLAN  
**PROJECT NO.:** 2022-01  
**PROJECT LOCATION:** SECTION 47, BLOCK 1, LOT 48  
**REVIEW DATE:** 27 MAY 2022  
**MEETING DATE:** 2 JUNE 2022  
**PROJECT REPRESENTATIVE:** TALCOTT ENGINEERING

1. This office's previous comments dated 28 January 2022 for the 3 February 2022 meeting should be addressed.
2. The applicant is requested to confirm that the Adjoiner's Notices have been sent out. Affidavit of mailing should be provided.
3. Notice of Intent for Lead Agency was circulated on 8 February 2022. NYS Office of Parks Recreation and Historic Preservation responded stating "No adverse impact".
4. The applicant has submitted renderings for the proposed project. Applicants notes that the proposal is for office or retail. It is noted that four garage bay doors are located to the rear of the structure, which may be conducive for use as a contractor's office/ small storage area.
5. Landscaping schematic has been provided by the applicant's representative which should be submitted to the Town's Landscape Architect consultant for review.

Respectfully submitted,

**MHE Engineering, D.P.C.**

A handwritten signature in blue ink that reads "Patrick J. Hines".

Patrick J. Hines  
Principal  
PJH/kbw

# Talcott Engineering

## DESIGN, PLLC

1 GARDNERTOWN ROAD ~ NEWBURGH, NY 12550  
(845) 569-8400\* ~ (fax) (845) 569-4583

Town of Newburgh  
Planning Board  
21 Hudson Valley Professional Plaza  
Newburgh, NY 12550

January 5, 2022

Attn: John Ewasutyn, Chairman

Re: Project Narrative  
Commercial Site Plan for O'Donnell  
NYS Route 52  
Town Project No. 2022-XX  
S-B-L: 47-1-48  
Job No. 20003-MDL

### COMMERCIAL SITE PLAN FOR O'DONNELL NARRATIVE

The subject parcel is a 11.12 acre lot, owned by Michael O'Donnell, located on NYS Route 52. The property is located in the B (Business) Zone, and is vacant. It is serviced by Town water and sewer.

The proposal is to build a 5,200 sf commercial building, which will contain offices, remove the offices, and/or offices. The plans also include new sewer and water service line, parking to accommodate the building. The project, as proposed, is in compliance with Zoning.

Most of the site is NYS Wetland NR-16 ,therefore, parking is placed in the front yard setback, which is consistent with existing development in the area. I request a waiver from the design guidelines for this.

The driveway entrance has been permitted and constructed.

Upon your authorization, I will deliver 12 sets of prints, applications, and EAF Long Forms along with the applicants' checks for escrow (\$ 4,200.00), application fees (\$ 3,000.00), and public hearing fee (\$ 150.00). I will deliver 1 set to Pat Hines and PDF 1 set to Dominic Cordisco.

Respectfully yours,

Charles T. Brown, P.E. – President  
Talcott Engineering Design, PLLC

PC; Michael O'Donnell, Owner  
Pat Hines  
Dominic Cordisco, Esq.

**TOWN OF NEWBURGH PLANNING BOARD**

**APPLICATION PACKAGE**

**for**

**SUBDIVISIONS**

**and**

**SITE PLANS**

**Procedures and Requirements**

**August 2005**

**TOWN OF NEWBURGH PLANNING BOARD  
308 GARDNERTOWN ROAD  
NEWBURGH, NEW YORK 12550  
(845) 564-7804  
fax: (845) 564-7802**

**August 2005**

**TO WHOM IT MAY CONCERN:**

This package of information and forms is provided to assist the applicant in the preparation of a submission of a site plan, subdivision or lot line change to the Town of Newburgh Planning Board. In most cases the application will be prepared initially by a licensed professional engineer, architect, surveyor or by a land planner. Since in almost every case such professional will be required for the process, they should be retained as early as possible.

Procedurally, the applicant should contact the Planning Board to discuss the potential project and obtain the necessary forms and regulations.

The Zoning and Subdivision Regulations of the Town of Newburgh require that the applicant must present plans to the Secretary of the Planning Board. When your application is complete, it will be placed on the next **AVAILABLE** agenda. Submittals must be handed in to the Planning Board Secretary at least 10 days prior to the next meeting, but the date of the appearance at a meeting will be determined by the next available time slot, not necessarily the next meeting. You will be notified of the date, time and place of your meeting.

A minimum of **FOURTEEN (14)** sets of **FOLDED PLANS** for a major or minor subdivision or a site plan must be submitted with a **COMPLETED** application, and **FIFTEEN (15)** sets of plans must be submitted if plans need to be submitted to the Town of Newburgh Traffic Consultant. This completed application must include a **LONG FORM OR FULL EAF** for every project except lot line changes, 2 lot subdivisions under 3 acres or site plans impacting less than one acre, along with a **NARRATIVE** of the proposed project. The narrative should include the action being taken, the size of the parcel, what zone the parcel is in, the water and sewer information, any Zoning Board of Appeals relief needed, and whether the parcel is on a private or town road. Complex or unusual projects should be discussed in greater detail.

Upon initial review of a Short Form, the Planning Board may require specific additional environmental information or the preparation of a Long Form. Long Form part 1 should be completed by the applicant. The Board will review and may modify Part 2 prior to making a decision on the SEQRA aspect of the project.

All fees for consulting and professional services that the Planning Board incurs during the review of the applications will be the responsibility of the applicant. An advance deposit for these fees will be required and will be placed in an escrow account with the Town. If the escrow account falls below the 40% of the initial deposit, the applicant will be required to immediately make an additional deposit to the escrow account prior to any further review of the project application by the Planning Board.

Very truly yours,

JOHN P. EWASUTYN, Chairman  
Town of Newburgh Planning Board

**TOWN OF NEWBURGH  
APPLICATION FOR  
SUBDIVISION/SITE PLAN REVIEW**

**RETURN TO:** Town of Newburgh Planning Board  
308 Gardnertown Road  
Newburgh, New York 12550

**DATE RECEIVED:** \_\_\_\_\_ **TOWN FILE NO:** 2022-03  
(Application fee returnable with this application)

**1. Title of Subdivision/Site Plan (Project name):**

COMMERCIAL SITE PLAN FOR O'DONNELL

**2. Owner of Lands to be reviewed:**

Name MICHAEL O'DONNELL  
Address 13 DEER RUN ROAD  
NEWBURGH, NY 12550  
Phone 845-728-9901

**3. Applicant Information (If different than owner):**

Name (SAME)  
Address \_\_\_\_\_  
\_\_\_\_\_

Representative CHARLES T BROWN, PE / TALCOTT ENGINEERING &  
Phone 845-569-8400  
Fax 845-569-4583  
Email TALCOTTDESIGN12@GMAIL.COM

**4. Subdivision/Site Plan prepared by:**

Name TALCOTT ENGINEERING  
Address 1 GARDNERTOWN ROAD  
NEWBURGH, NY 12550  
Phone/Fax 845-569-8400 / 845-569-4583

**5. Location of lands to be reviewed:**

RT 52

**6. Zone** B **Fire District** ORANGE LAKE  
**Acres** 11.17 **School District** NEWBURGH

**7. Tax Map: Section** 47 **Block** 1 **Lot** 48

8. Project Description and Purpose of Review:

Number of existing lots \_\_\_\_\_ Number of proposed lots \_\_\_\_\_

Lot line change \_\_\_\_\_

Site plan review  \_\_\_\_\_

Clearing and grading \_\_\_\_\_

Other \_\_\_\_\_

**PROVIDE A WRITTEN SINGLE PAGE DESCRIPTION OR NARRATIVE OF THE PROJECT**

9. Easements or other restrictions on property:

(Describe generally) NONE \_\_\_\_\_

10. The undersigned hereby requests approval by the Planning Board of the above identified application and scheduling for an appearance on an agenda:

Signature [Handwritten Signature] Title OWNER

Date: 2/8/21

**NOTE:** If property abuts and has its access to a County or State Highway or road, the following information must be placed on the subdivision map or site plan: entrance location, entrance profile, sizing of pipe (minimum length of pipe to be 24 feet).

TOWN OF NEWBURGH PLANNING BOARD

O'DOWDALL SITE PLAN  
PROJECT NAME

CHECKLIST FOR MAJOR/MINOR SUBDIVISION AND/OR SITE PLAN

I. The following items shall be submitted with a COMPLETED Planning Board Application Form.

1.  Environmental Assessment Form As Required
2.  Proxy Statement
3.  Application Fees
4.  Completed Checklist (Automatic rejection of application without checklist)

II. The following checklist items shall be incorporated on the Subdivision Plat or Site Plan prior to consideration of being placed on the Planning Board Agenda. Non-submittal of the checklist will result in application rejection.

1.  Name and address of applicant
2.  Name and address of owner (if different from applicant)
3.  Subdivision or Site Plan and Location
4.  Tax Map Data (Section-Block-Lot)
5.  Location map at a scale of 1" = 2,000 ft. or less on a tax map or USCGS map base only with property outlined
6.  Zoning table showing what is required in the particular zone and what applicant is proposing. A table is to be provided for each proposed lot
7.  Show zoning boundary if any portion of proposed site is within or adjacent to a different zone
8.  Date of plan preparation and/or plan revisions
9.  Scale the plan is drawn to (Max 1" = 100')
10.  North Arrow pointing generally up



11.  Surveyor,s Certification
12.  Surveyor's seal and signature
13.  Name of adjoining owners
14.  Wetlands and 100 ft. buffer zone with an appropriate note regarding D.E.C. or A.C.O.E. requirements
15. N/A Flood plain boundaries
16. N/A Certified sewerage system design and placement by a Licensed Professional Engineer must be shown on plans in accordance with Local Law #1 1989
17.  Metes and bounds of all lots
18.  Name and width of adjacent streets; the road boundary is to be a minimum of 25 ft. from the physical center line of the street
19. N/A Show existing or proposed easements (note restrictions)
20. N/A Right-of-way width and Rights of Access and Utility Placement
21. N/A Road profile and typical section (minimum traveled surface, excluding shoulders, is to be 18 ft. wide)
22.  Lot area (in sq. ft. for each lot less than 2 acres)
23. N/A Number of lots including residual lot
24.  Show any existing waterways
25. N/A A note stating a road maintenance agreement is to be filed in the County Clerk's Office where applicable
26.  Applicable note pertaining to owners review and concurrence with plat together with owner's signature
27.  Show any improvements, i.e. drainage systems, water lines, sewer lines, etc.
28. N/A Show all existing houses, accessory structures, wells and septic systems on and within 200 ft. of the parcel to be subdivided
29.  Show topographical data with 2 or 5 ft. contours on initial submission

- 30. N/A Indicate any reference to a previous subdivision, i.e. filed map number, date and previous lot number
- 31. N/A If a private road, Town Board approval of name is required, and notes on the plan that no town services will be provided and a street sign (per town specs) is to be furnished and installed
- 32. N/A Number of acres to be cleared or timber harvested
- 33. N/A Estimated or known cubic yards of material to be excavated and removed from the site
- 34. N/A Estimated or known cubic yards of fill required
- 35. N/A The amount of grading expected or known to be required to bring the site to readiness
- 36.  Type and amount of site preparation which falls within the 100 ft. buffer strip of wetlands or within the Critical Environmental Area. Please explain in sq. ft. or cubic yards.  
10,761 SF  

---



---
- 37. N/A Any amount of site preparation within a 100 year floodplain or any water course on the site. Please explain in sq. ft. or cubic yards.  

---



---

The plan for the proposed subdivision or site has been prepared in accordance with this checklist.

By:   
 Licensed Professional

Date: 1/6/2022

This list is designed to be a guide ONLY. The Town of Newburgh Planning Board may require additional notes or revisions prior to granting approval.

**RE: TOWN OF NEWBURGH CLEARING AND GRADING LAW**

The Town of Newburgh Clearing and Grading Control Law requires a separate permit for most site preparation activities, including clearing, grading, tree cutting, excavating and filling. Site preparation activities performed following site plan or subdivision approval by the Planning Board may be exempt from the permit application, public hearing, fee and bonding requirements of the law provided the subdivision or site plan application has been reviewed for conformance with the clearing and grading law and the approval conditioned on compliance with the standards set forth in the law. Completion of the attached form will enable the Planning Board to review your application for conformance with the law's requirements. In the event it is not completed you may be required to apply for a separated permit for your site preparation activities. A sediment and erosion control plan and a plan showing the areas to be cleared, filled, graded or subjected to tree cutting, the types of vegetation affected and the proposed disposition of the destroyed vegetation must accompany the form. A SEQRA long form or full EAF should be utilized to discuss any environmental impacts and must accompany the application.

**TOWN OF NEWBURGH  
APPLICATION FOR CLEARING AND GRADING**

Name of applicant: \_\_\_\_\_

Name of owner on premises: \_\_\_\_\_

Address of owner: \_\_\_\_\_

Telephone number of owner: \_\_\_\_\_

Telephone number of applicant: \_\_\_\_\_

State whether applicant is owner, lessee, agent, architect, engineer or contractor:

\_\_\_\_\_  
Location of land on which proposed work will be done: \_\_\_\_\_

Section: \_\_\_\_\_ Block: \_\_\_\_\_ Lot: \_\_\_\_\_ Sub. Div.: \_\_\_\_\_

Zoning District of Property: \_\_\_\_\_ Size of Lot: \_\_\_\_\_

Area of lot to be cleared or graded: \_\_\_\_\_

Proposed completion of date: \_\_\_\_\_

Name of contractor/agent, if different than owner: \_\_\_\_\_

Address: \_\_\_\_\_

Telephone number: \_\_\_\_\_

Date of Planning Board Approval: \_\_\_\_\_ (if required)

I hereby agree to hold the Town of Newburgh harmless from any claims arising from the proposed activity.

Signature of owner: \_\_\_\_\_ Date: \_\_\_\_\_

Signature of applicant (if different than owner): \_\_\_\_\_

**TOWN ACTION:**

Examined: \_\_\_\_\_ 20 \_\_\_\_\_

Approved: \_\_\_\_\_ 20 \_\_\_\_\_

Disapproved: \_\_\_\_\_ 20 \_\_\_\_\_

## **FEE LAW SUMMARY**

### **PENDING APPLICATIONS**

All applicants with matters pending before the Planning Board as of the effective date of this local law shall be required to post as escrow in the manner and upon the terms and conditions set forth below:

- (a) The Planning Board, in consultation with the applicant, shall compute the amount of the escrow to be posted with the Town. Such amount shall be reasonably related to the costs attendant to the Town's review of the application as of the effective date of this local law. Under no circumstances shall the escrow include amounts attributable to any costs incurred by the Town prior to the effective date of this local law.
- (b) Once computed and established by Resolution of the Planning Board, the applicant shall, within fifteen (15) days of said resolution, post escrow fees with the Secretary of the Planning Board. Failure to deliver the said escrow fees may result in delay of the further processing of the application.

### **SEVERABILITY**

In the event a court of law determined that any provision of this chapter is unenforceable, then only that provision shall be affected and all other provisions shall be fully enforceable.

### **EFFECTIVE DATE:**

This local law shall take effect immediately upon filing in the Office of the Secretary of State.

**FEE ACKNOWLEDGEMENT**

The town of Newburgh Municipal Code sets forth the schedule of fees for applications to the Planning Board. The signing of this application indicates your acknowledgement of responsibility for payment of these fees to the Planning Board for review of this application, including, but not limited to escrow fees for professional services (planner/consultant, engineering, legal), public hearing and site inspection. Applicant's submissions and resubmissions are not complete and will not be considered by the planning board or placed upon its agenda unless all outstanding fees have been paid. Fees incurred after the stamping of plans will remain the responsibility of the applicant prior to approval of a building permit or certificate of occupancy. Fee schedules are available from the Planning Board Secretary and are on the Town's website.

Michael O'Donnell  
APPLICANT'S NAME (printed)

  
APPLICANTS SIGNATURE

2/8/21  
DATE

Note: if the property abuts and has access to a County or State Highway or road, the following information must be place on the subdivision map: entrance location, entrance profile, sizing of drainage pipe (minimum length of pipe to be twenty-four (24) feet).

PROXY

(OWNER) MIKE O'DONNELL, DEPOSES AND SAYS THAT HE/SHE  
RESIDES AT 13 DEER RUN RD NEWBURGH, NY 12550  
IN THE COUNTY OF ORANGE  
AND STATE OF NEW YORK  
AND THAT HE/SHE IS THE OWNER IN FEE OF \_\_\_\_\_

WHICH IS THE PREMISES DESCRIBED IN THE FOREGOING  
APPLICATION AS DESCRIBED THEREIN TO THE TOWN OF NEWBURGH  
PLANNING BOARD AND FALCOTT ENGINEERING IS AUTHORIZED  
TO REPRESENT THEM AT MEETINGS OF SAID BOARD.

DATED: 2/8/2021

  
OWNERS SIGNATURE

CHARLES BROWN, PE

MIKE O'DONNELL  
OWNERS NAME (printed)

\_\_\_\_\_  
\_\_\_\_\_

  
WITNESS' SIGNATURE

NAMES OF ADDITIONAL  
REPRESENTATIVES

Michael Capobianchi  
WITNESS' NAME (printed)

TAMMY L. MANCINELLI  
Notary Public, State of New York  
No. 01MA6026211  
Qualified in Orange County  
Commission Expires June 14, 2023

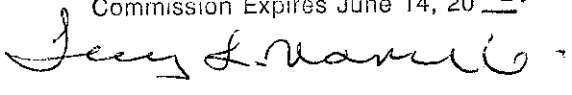

**PLANNING BOARD DISCLAIMER STATEMENT**  
**TO APPLICANTS**

The applicant is advised that the Town of Newburgh Municipal Code, which contains the Town's Zoning Law, is subject to amendment. Submission of an application to this Board does not grant the applicant any right to continued review under the Code's current standards and requirements. It is possible that the applicant will be required to meet changed standards or new Code requirements made while the application is pending.

An approval by this Board does not constitute permission, nor grant any right to connect to or use municipal services such as sewer, water or roads. It is the applicant's responsibility to apply for and obtain the Town of Newburgh and other agency approvals not within this Board's authority to grant.

The applicant hereby acknowledges, consents, and agrees to the above.

2/8/21  
**DATED**

Michael O'Donnell  
**APPLICANT'S NAME (printed)**

  
**APPLICANT'S SIGNATURE**



**DISCLOSURE ADDENDUM STATEMENT TO APPLICATION,  
PETITION AND REQUEST**

Mindful of the provisions of Section 809 of the General Municipal Law of the State of New York, and of the Penal provisions thereof as well, the undersigned applicant states that no State Officer, Officer or Employee of the Town of Newburgh, or Orange County, has any interest, financial or otherwise, in this application or with, or in the applicant as defined in said Statute, except the following person or persons who is or are represented to have only the following type of interest, in the nature and to the extent hereinafter indicated:

                     **NONE**

                     **NAME, ADDRESS, RELATIONSHIP OR INTEREST**  
(financial or otherwise)

\_\_\_\_\_

\_\_\_\_\_

\_\_\_\_\_

This disclosure addendum statement is annexed to and made a part of the petition, application and request made by the undersigned applicant to the following Board or Officer of the Town of Newburgh.

- TOWN BOARD**
- PLANNING BOARD**
- ZONING BOARD OF APPEALS**
- ZONING ENFORCEMENT OFFICER**
- BUILDING INSPECTOR**
- OTHER**

                     **2/8/21**  
**DATED**

  
\_\_\_\_\_  
**INDIVIDUAL APPLICANT**  
*Michael O'Donnell*

\_\_\_\_\_  
**CORPORATE OR PARTNERSHIP APPLICANT**

**BY:** \_\_\_\_\_  
(Pres.) (Partner) (Vice-Pres.)  
(Sec.) (Treas.)

## AGRICULTURAL NOTE

**(Required to be placed on all plans where property lies within 500 feet of land in active agricultural production or operation)**

Property adjacent to lots ( 1 ) is in active agricultural operation and production and residents must be aware that such property is protected by New York State "Right to Farm Laws" as regulated by the Department of Agriculture and Markets. From time to time during and prior to the normal growing season land and crops may be sprayed from the ground or by air, manure may be applied, and periodic noise may occur from machinery operation at various times throughout the day. Residents should be aware of this action by the adjacent property owners.

( 1 ) Specific lots adjacent to the active farming area which are impacted shall be inserted in this space.

**AGRICULTURAL DATA STATEMENT**

(Required pursuant to Agricultural and Markets Law §305-a for applications for site plan approvals, use variances and subdivision approvals that will occur on property within a County Agricultural District containing an active farm operation or on property with boundaries within five hundred feet of an active farm operation located in a County Agricultural District)

**Name and address of the applicant:** \_\_\_\_\_

\_\_\_\_\_

**Description of the proposed project:** \_\_\_\_\_

\_\_\_\_\_

**Location of the proposed project:** \_\_\_\_\_

\_\_\_\_\_

**Name(s) and address(es) of any owner(s) of land within a County Agricultural District containing active farming operations and located within five hundred feet of the boundary of the project property:** \_\_\_\_\_

\_\_\_\_\_

\_\_\_\_\_

\_\_\_\_\_

**A tax map or other map showing the site of the proposed project relative to the location of the identified farm operations must be attached to this form.**

\_\_\_\_\_

**APPLICANT'S SIGNATURE**

\_\_\_\_\_

**DATE**

## ARCHITECTURAL REVIEW

The Town of Newburgh Planning Board had been authorized to act as the Architectural Review Board for all: site plans, projects involving ten or more dwelling units, and any construction that would affect the character of a neighborhood under Section §185-59 of the Town Code (Zoning Law).

In order to perform this task, at some point prior to final approval, the applicant shall provide the Planning Board with elevations of buildings for all sides and a written (separately or on drawings) description of the materials, colors and textures to be used in construction. Plans shall also include topographical information and any screening of portions of the buildings, either existing or proposed.

Samples of the material and colors to be used shall either be submitted to the Planning Board or brought to the meeting at which architectural review will be discussed.

**ARCHITECTURAL REVIEW FORM**  
**TOWN OF NEWBURGH PLANNING BOARD**

**DATE:** \_\_\_\_\_

**NAME OF PROJECT:** \_\_\_\_\_

The applicant is to submit in writing the following items prior to signing of the site plans.

**EXTERIOR FINISH (skin of the building):**

Type (steel, wood, block, split block, etc.)

\_\_\_\_\_

**COLOR OF THE EXTERIOR OF BUILDING:**

\_\_\_\_\_

**ACCENT TRIM:**

Location: \_\_\_\_\_

Color: \_\_\_\_\_

Type (material): \_\_\_\_\_

**PARAPET (all roof top mechanicals are to be screened on all four sides):**

\_\_\_\_\_

**ROOF:**

Type (gabled, flat, etc.): \_\_\_\_\_

Material (shingles, metal, tar & sand, etc.): \_\_\_\_\_

Color: \_\_\_\_\_

**WINDOWS/SHUTTERS:**

Color (also trim if different): \_\_\_\_\_

Type: \_\_\_\_\_

**DOORS:**

Color: \_\_\_\_\_

Type (if different than standard door entrée): \_\_\_\_\_

**SIGN:**

Color: \_\_\_\_\_

Material: \_\_\_\_\_

Square footage of signage of site: \_\_\_\_\_

\_\_\_\_\_

Please print name and title (owner, agent, builder, superintendent of job, etc.)

\_\_\_\_\_

Signature

## LIST OF ADJACENT PROPERTY OWNERS

Within ten business days following the applicant's first appearance before the Planning Board, the applicant shall forward a letter prepared by the Planning Board or an authorized agent of the Planning Board to all property owners within 500 feet of the land involved in the application, as the names of such owners appear on the last completed assessment roll of the Town, notifying the property owners of the receipt of the plat and application, by first class mail. **The list of property owners shall be provided to the applicant from the Planning Board, through the Town Assessor's office.** The applicant shall thereafter submit a duly executed, notarized affidavit of mailing to the Planning Board. Further appearances before the Planning Board shall be prohibited until an affidavit meeting the requirements has been delivered. In the event a modification to an application proposes an increase in the number of lots or the relocation of a proposed road or drainage basin to a location adjacent to an adjoining property, then a supplementary letter shall be required to be forwarded in the same manner advising of the modification.

**Full Environmental Assessment Form  
Part 1 - Project and Setting**

**Instructions for Completing Part 1**

**Part 1 is to be completed by the applicant or project sponsor.** Responses become part of the application for approval or funding, are subject to public review, and may be subject to further verification.

Complete Part 1 based on information currently available. If additional research or investigation would be needed to fully respond to any item, please answer as thoroughly as possible based on current information; indicate whether missing information does not exist, or is not reasonably available to the sponsor; and, when possible, generally describe work or studies which would be necessary to update or fully develop that information.

Applicants/sponsors must complete all items in Sections A & B. In Sections C, D & E, most items contain an initial question that must be answered either "Yes" or "No". If the answer to the initial question is "Yes", complete the sub-questions that follow. If the answer to the initial question is "No", proceed to the next question. Section F allows the project sponsor to identify and attach any additional information. Section G requires the name and signature of the applicant or project sponsor to verify that the information contained in Part 1 is accurate and complete.

**A. Project and Applicant/Sponsor Information.**

Name of Action or Project: O'DONNELL SITE PLAN			TED # 20003		
Project Location (describe, and attach a general location map): NYS ROUTE 52, 300' SW OF MONARCH DRIVE, TOWN OF NEWBURGH					
Brief Description of Proposed Action (include purpose or need): SITE PLAN FOR A 5200 SF COMMERCIAL BUILDING WITH TOWN WATER AND SEWER AND DRIVEWAY TO NYS ROUTE 52.					
Name of Applicant/Sponsor: MICHAEL O'DONNELL			Telephone: 845-728-9901		
			E-Mail: VALLEYCONTRACTINGINC@MSN.COM		
Address: 444 SOUTH PLANK ROAD					
City/PO: NEWBURGH			State: NY		Zip Code: 12550
Project Contact (if not same as sponsor; give name and title/role): (SAME)			Telephone:		
			E-Mail:		
Address:					
City/PO:			State:		Zip Code:
Property Owner (if not same as sponsor): (SAME)			Telephone:		
			E-Mail:		
Address:					
City/PO:			State:		Zip Code:



**B. Government Approvals**

**B. Government Approvals, Funding, or Sponsorship.** ("Funding" includes grants, loans, tax relief, and any other forms of financial assistance.)

Government Entity	If Yes: Identify Agency and Approval(s) Required	Application Date (Actual or projected)
a. City Counsel, Town Board, <input type="checkbox"/> Yes <input checked="" type="checkbox"/> No or Village Board of Trustees		
b. City, Town or Village <input checked="" type="checkbox"/> Yes <input type="checkbox"/> No Planning Board or Commission	PLANNING BOARD SITE PLAN	12-10-2021
c. City, Town or <input type="checkbox"/> Yes <input checked="" type="checkbox"/> No Village Zoning Board of Appeals		
d. Other local agencies <input type="checkbox"/> Yes <input checked="" type="checkbox"/> No		
e. County agencies <input type="checkbox"/> Yes <input checked="" type="checkbox"/> No		
f. Regional agencies <input type="checkbox"/> Yes <input checked="" type="checkbox"/> No		
g. State agencies <input checked="" type="checkbox"/> Yes <input type="checkbox"/> No	NYSDEC WETLANDS (APPROVED) NYS DOT DRIVEWAY (APPROVED)	
h. Federal agencies <input type="checkbox"/> Yes <input checked="" type="checkbox"/> No		
i. Coastal Resources.		
i. Is the project site within a Coastal Area, or the waterfront area of a Designated Inland Waterway?		<input type="checkbox"/> Yes <input checked="" type="checkbox"/> No
ii. Is the project site located in a community with an approved Local Waterfront Revitalization Program?		<input type="checkbox"/> Yes <input checked="" type="checkbox"/> No
iii. Is the project site within a Coastal Erosion Hazard Area?		<input type="checkbox"/> Yes <input checked="" type="checkbox"/> No

**C. Planning and Zoning**

**C.1. Planning and zoning actions.**

Will administrative or legislative adoption, or amendment of a plan, local law, ordinance, rule or regulation be the only approval(s) which must be granted to enable the proposed action to proceed?  Yes  No

- If Yes, complete sections C, F and G.
- If No, proceed to question C.2 and complete all remaining sections and questions in Part 1

**C.2. Adopted land use plans.**

a. Do any municipally- adopted (city, town, village or county) comprehensive land use plan(s) include the site where the proposed action would be located?  Yes  No

If Yes, does the comprehensive plan include specific recommendations for the site where the proposed action would be located?  Yes  No

b. Is the site of the proposed action within any local or regional special planning district (for example: Greenway; Brownfield Opportunity Area (BOA); designated State or Federal heritage area; watershed management plan; or other?)  Yes  No

If Yes, identify the plan(s):

\_\_\_\_\_

\_\_\_\_\_

c. Is the proposed action located wholly or partially within an area listed in an adopted municipal open space plan, or an adopted municipal farmland protection plan?  Yes  No

If Yes, identify the plan(s):

\_\_\_\_\_

\_\_\_\_\_

**C.3. Zoning**

a. Is the site of the proposed action located in a municipality with an adopted zoning law or ordinance.  Yes  No  
 If Yes, what is the zoning classification(s) including any applicable overlay district?  
 B-BUSINESS

b. Is the use permitted or allowed by a special or conditional use permit?  Yes  No

c. Is a zoning change requested as part of the proposed action?  Yes  No  
 If Yes,  
 i. What is the proposed new zoning for the site? \_\_\_\_\_

**C.4. Existing community services.**

a. In what school district is the project site located? NEWBURGH

b. What police or other public protection forces serve the project site?  
 TOWN OF NEWBURGH

c. Which fire protection and emergency medical services serve the project site?  
 ORANGE LAKE FIRE DEPARTMENT

d. What parks serve the project site?  
 ALGONQUIN, CRONOMER HILL

**D. Project Details**

**D.1. Proposed and Potential Development**

a. What is the general nature of the proposed action (e.g., residential, industrial, commercial, recreational; if mixed, include all components)? COMMERCIAL

b. a. Total acreage of the site of the proposed action? \_\_\_\_\_ 11.17 acres  
 b. Total acreage to be physically disturbed? \_\_\_\_\_ 0.71 acres  
 c. Total acreage (project site and any contiguous properties) owned or controlled by the applicant or project sponsor? \_\_\_\_\_ 11.17 acres

c. Is the proposed action an expansion of an existing project or use?  Yes  No  
 i. If Yes, what is the approximate percentage of the proposed expansion and identify the units (e.g., acres, miles, housing units, square feet)? % \_\_\_\_\_ Units: \_\_\_\_\_

d. Is the proposed action a subdivision, or does it include a subdivision?  Yes  No  
 If Yes,  
 i. Purpose or type of subdivision? (e.g., residential, industrial, commercial; if mixed, specify types) \_\_\_\_\_  
 ii. Is a cluster/conservation layout proposed?  Yes  No  
 iii. Number of lots proposed? \_\_\_\_\_  
 iv. Minimum and maximum proposed lot sizes? Minimum \_\_\_\_\_ Maximum \_\_\_\_\_

e. Will the proposed action be constructed in multiple phases?  Yes  No  
 i. If No, anticipated period of construction: \_\_\_\_\_ 10 months  
 ii. If Yes:  
 • Total number of phases anticipated \_\_\_\_\_  
 • Anticipated commencement date of phase 1 (including demolition) \_\_\_\_\_ month \_\_\_\_\_ year  
 • Anticipated completion date of final phase \_\_\_\_\_ month \_\_\_\_\_ year  
 • Generally describe connections or relationships among phases, including any contingencies where progress of one phase may determine timing or duration of future phases: \_\_\_\_\_  
 \_\_\_\_\_  
 \_\_\_\_\_

f. Does the project include new residential uses?  Yes  No  
 If Yes, show numbers of units proposed.

	<u>One Family</u>	<u>Two Family</u>	<u>Three Family</u>	<u>Multiple Family (four or more)</u>
Initial Phase	_____	_____	_____	_____
At completion of all phases	_____	_____	_____	_____

g. Does the proposed action include new non-residential construction (including expansions)?  Yes  No  
 If Yes,

i. Total number of structures 1

ii. Dimensions (in feet) of largest proposed structure: 20 height; 40 width; and 130 length

iii. Approximate extent of building space to be heated or cooled: 5,200 square feet

h. Does the proposed action include construction or other activities that will result in the impoundment of any liquids, such as creation of a water supply, reservoir, pond, lake, waste lagoon or other storage?  Yes  No  
 If Yes,

i. Purpose of the impoundment: \_\_\_\_\_

ii. If a water impoundment, the principal source of the water:  Ground water  Surface water streams  Other specify: \_\_\_\_\_

iii. If other than water, identify the type of impounded/contained liquids and their source. \_\_\_\_\_

iv. Approximate size of the proposed impoundment. Volume: \_\_\_\_\_ million gallons; surface area: \_\_\_\_\_ acres

v. Dimensions of the proposed dam or impounding structure: \_\_\_\_\_ height; \_\_\_\_\_ length

vi. Construction method/materials for the proposed dam or impounding structure (e.g., earth fill, rock, wood, concrete): \_\_\_\_\_

**D.2. Project Operations**

a. Does the proposed action include any excavation, mining, or dredging, during construction, operations, or both? (Not including general site preparation, grading or installation of utilities or foundations where all excavated materials will remain onsite)  Yes  No  
 If Yes:

i. What is the purpose of the excavation or dredging? \_\_\_\_\_

ii. How much material (including rock, earth, sediments, etc.) is proposed to be removed from the site?

- Volume (specify tons or cubic yards): \_\_\_\_\_
- Over what duration of time? \_\_\_\_\_

iii. Describe nature and characteristics of materials to be excavated or dredged, and plans to use, manage or dispose of them. \_\_\_\_\_

iv. Will there be onsite dewatering or processing of excavated materials?  Yes  No  
 If yes, describe. \_\_\_\_\_

v. What is the total area to be dredged or excavated? \_\_\_\_\_ acres

vi. What is the maximum area to be worked at any one time? \_\_\_\_\_ acres

vii. What would be the maximum depth of excavation or dredging? \_\_\_\_\_ feet

viii. Will the excavation require blasting?  Yes  No

ix. Summarize site reclamation goals and plan: \_\_\_\_\_

b. Would the proposed action cause or result in alteration of, increase or decrease in size of, or encroachment into any existing wetland, waterbody, shoreline, beach or adjacent area?  Yes  No  
 If Yes:

i. Identify the wetland or waterbody which would be affected (by name, water index number, wetland map number or geographic description): \_\_\_\_\_

ii. Describe how the proposed action would affect that waterbody or wetland, e.g. excavation, fill, placement of structures, or alteration of channels, banks and shorelines. Indicate extent of activities, alterations and additions in square feet or acres:

\_\_\_\_\_  
\_\_\_\_\_  
\_\_\_\_\_

iii. Will the proposed action cause or result in disturbance to bottom sediments?  Yes  No

If Yes, describe: \_\_\_\_\_

iv. Will the proposed action cause or result in the destruction or removal of aquatic vegetation?  Yes  No

If Yes:

- acres of aquatic vegetation proposed to be removed: \_\_\_\_\_
- expected acreage of aquatic vegetation remaining after project completion: \_\_\_\_\_
- purpose of proposed removal (e.g. beach clearing, invasive species control, boat access): \_\_\_\_\_
- proposed method of plant removal: \_\_\_\_\_
- if chemical/herbicide treatment will be used, specify product(s): \_\_\_\_\_

v. Describe any proposed reclamation/mitigation following disturbance: \_\_\_\_\_

c. Will the proposed action use, or create a new demand for water?  Yes  No

If Yes:

i. Total anticipated water usage/demand per day: \_\_\_\_\_ 420 gallons/day

ii. Will the proposed action obtain water from an existing public water supply?  Yes  No

If Yes:

- Name of district or service area: NEWBURGH CONSOLIDATED WATER DISTRICT
- Does the existing public water supply have capacity to serve the proposal?  Yes  No
- Is the project site in the existing district?  Yes  No
- Is expansion of the district needed?  Yes  No
- Do existing lines serve the project site?  Yes  No

iii. Will line extension within an existing district be necessary to supply the project?  Yes  No

If Yes:

- Describe extensions or capacity expansions proposed to serve this project: \_\_\_\_\_
- Source(s) of supply for the district: \_\_\_\_\_

iv. Is a new water supply district or service area proposed to be formed to serve the project site?  Yes  No

If, Yes:

- Applicant/sponsor for new district: \_\_\_\_\_
- Date application submitted or anticipated: \_\_\_\_\_
- Proposed source(s) of supply for new district: \_\_\_\_\_

v. If a public water supply will not be used, describe plans to provide water supply for the project: \_\_\_\_\_

vi. If water supply will be from wells (public or private), what is the maximum pumping capacity: \_\_\_\_\_ gallons/minute.

d. Will the proposed action generate liquid wastes?  Yes  No

If Yes:

i. Total anticipated liquid waste generation per day: \_\_\_\_\_ 420 gallons/day

ii. Nature of liquid wastes to be generated (e.g., sanitary wastewater, industrial; if combination, describe all components and approximate volumes or proportions of each): \_\_\_\_\_

SANITARY WASTEWATER

iii. Will the proposed action use any existing public wastewater treatment facilities?  Yes  No

If Yes:

- Name of wastewater treatment plant to be used: CITY OF NEWBURGH SEWAGE TREATMENT PLANT
- Name of district: TOWN OF NEWBURGH
- Does the existing wastewater treatment plant have capacity to serve the project?  Yes  No
- Is the project site in the existing district?  Yes  No
- Is expansion of the district needed?  Yes  No

• Do existing sewer lines serve the project site?  Yes  No  
 • Will a line extension within an existing district be necessary to serve the project?  Yes  No  
 If Yes:  
 • Describe extensions or capacity expansions proposed to serve this project: \_\_\_\_\_  
 \_\_\_\_\_  
 \_\_\_\_\_

iv. Will a new wastewater (sewage) treatment district be formed to serve the project site?  Yes  No  
 If Yes:  
 • Applicant/sponsor for new district: \_\_\_\_\_  
 • Date application submitted or anticipated: \_\_\_\_\_  
 • What is the receiving water for the wastewater discharge? \_\_\_\_\_

v. If public facilities will not be used, describe plans to provide wastewater treatment for the project, including specifying proposed receiving water (name and classification if surface discharge or describe subsurface disposal plans):  
 \_\_\_\_\_  
 \_\_\_\_\_  
 \_\_\_\_\_

vi. Describe any plans or designs to capture, recycle or reuse liquid waste: \_\_\_\_\_  
 \_\_\_\_\_  
 \_\_\_\_\_

e. Will the proposed action disturb more than one acre and create stormwater runoff, either from new point sources (i.e. ditches, pipes, swales, curbs, gutters or other concentrated flows of stormwater) or non-point source (i.e. sheet flow) during construction or post construction?  Yes  No  
 If Yes:  
 i. How much impervious surface will the project create in relation to total size of project parcel?  
 \_\_\_\_\_ Square feet or 0.65 acres (impervious surface)  
 \_\_\_\_\_ Square feet or 11.17 acres (parcel size)  
 ii. Describe types of new point sources. ROOF DOWNSPOUTS  
 \_\_\_\_\_  
 \_\_\_\_\_  
 iii. Where will the stormwater runoff be directed (i.e. on-site stormwater management facility/structures, adjacent properties, groundwater, on-site surface water or off-site surface waters)?  
 \_\_\_\_\_

**DEC WETLAND**  
 \_\_\_\_\_  
 • If to surface waters, identify receiving water bodies or wetlands: \_\_\_\_\_  
NB-22  
 \_\_\_\_\_  
 • Will stormwater runoff flow to adjacent properties?  Yes  No

iv. Does the proposed plan minimize impervious surfaces, use pervious materials or collect and re-use stormwater?  Yes  No

f. Does the proposed action include, or will it use on-site, one or more sources of air emissions, including fuel combustion, waste incineration, or other processes or operations?  Yes  No  
 If Yes, identify:  
 i. Mobile sources during project operations (e.g., heavy equipment, fleet or delivery vehicles)  
 \_\_\_\_\_  
 ii. Stationary sources during construction (e.g., power generation, structural heating, batch plant, crushers)  
 \_\_\_\_\_  
 iii. Stationary sources during operations (e.g., process emissions, large boilers, electric generation)  
 \_\_\_\_\_

g. Will any air emission sources named in D.2.f (above), require a NY State Air Registration, Air Facility Permit, or Federal Clean Air Act Title IV or Title V Permit?  Yes  No  
 If Yes:  
 i. Is the project site located in an Air quality non-attainment area? (Area routinely or periodically fails to meet ambient air quality standards for all or some parts of the year)  Yes  No  
 ii. In addition to emissions as calculated in the application, the project will generate:  
 • \_\_\_\_\_ Tons/year (short tons) of Carbon Dioxide (CO<sub>2</sub>)  
 • \_\_\_\_\_ Tons/year (short tons) of Nitrous Oxide (N<sub>2</sub>O)  
 • \_\_\_\_\_ Tons/year (short tons) of Perfluorocarbons (PFCs)  
 • \_\_\_\_\_ Tons/year (short tons) of Sulfur Hexafluoride (SF<sub>6</sub>)  
 • \_\_\_\_\_ Tons/year (short tons) of Carbon Dioxide equivalent of Hydroflouorocarbons (HFCs)  
 • \_\_\_\_\_ Tons/year (short tons) of Hazardous Air Pollutants (HAPs)

h. Will the proposed action generate or emit methane (including, but not limited to, sewage treatment plants, landfills, composting facilities)?  Yes  No  
 If Yes:  
 i. Estimate methane generation in tons/year (metric): \_\_\_\_\_  
 ii. Describe any methane capture, control or elimination measures included in project design (e.g., combustion to generate heat or electricity, flaring): \_\_\_\_\_

---

i. Will the proposed action result in the release of air pollutants from open-air operations or processes, such as quarry or landfill operations?  Yes  No  
 If Yes: Describe operations and nature of emissions (e.g., diesel exhaust, rock particulates/dust): \_\_\_\_\_

---

j. Will the proposed action result in a substantial increase in traffic above present levels or generate substantial new demand for transportation facilities or services?  Yes  No  
 If Yes:  
 i. When is the peak traffic expected (Check all that apply):  Morning  Evening  Weekend  
 Randomly between hours of \_\_\_\_\_ to \_\_\_\_\_.  
 ii. For commercial activities only, projected number of truck trips/day and type (e.g., semi trailers and dump trucks): \_\_\_\_\_  
 \_\_\_\_\_  
 iii. Parking spaces: Existing \_\_\_\_\_ Proposed \_\_\_\_\_ Net increase/decrease \_\_\_\_\_  
 iv. Does the proposed action include any shared use parking?  Yes  No  
 v. If the proposed action includes any modification of existing roads, creation of new roads or change in existing access, describe: \_\_\_\_\_  
 vi. Are public/private transportation service(s) or facilities available within ½ mile of the proposed site?  Yes  No  
 vii. Will the proposed action include access to public transportation or accommodations for use of hybrid, electric or other alternative fueled vehicles?  Yes  No  
 viii. Will the proposed action include plans for pedestrian or bicycle accommodations for connections to existing pedestrian or bicycle routes?  Yes  No

---

k. Will the proposed action (for commercial or industrial projects only) generate new or additional demand for energy?  Yes  No  
 If Yes:  
 i. Estimate annual electricity demand during operation of the proposed action: \_\_\_\_\_  
 2700 kWh  
 ii. Anticipated sources/suppliers of electricity for the project (e.g., on-site combustion, on-site renewable, via grid/local utility, or other): \_\_\_\_\_  
 GRID/LOCAL UTILITY  
 iii. Will the proposed action require a new, or an upgrade, to an existing substation?  Yes  No

---

l. Hours of operation. Answer all items which apply.  
 i. During Construction:  
 • Monday - Friday: \_\_\_\_\_ 8AM TO 6PM  
 • Saturday: \_\_\_\_\_ 8AM TO 6PM  
 • Sunday: \_\_\_\_\_  
 • Holidays: \_\_\_\_\_  
 ii. During Operations:  
 • Monday - Friday: \_\_\_\_\_ 9AM TO 5PM  
 • Saturday: \_\_\_\_\_  
 • Sunday: \_\_\_\_\_  
 • Holidays: \_\_\_\_\_

m. Will the proposed action produce noise that will exceed existing ambient noise levels during construction, operation, or both?  Yes  No  
 If yes:  
 i. Provide details including sources, time of day and duration:  
 \_\_\_\_\_  
 \_\_\_\_\_

ii. Will the proposed action remove existing natural barriers that could act as a noise barrier or screen?  Yes  No  
 Describe: \_\_\_\_\_  
 \_\_\_\_\_

---

n. Will the proposed action have outdoor lighting?  Yes  No  
 If yes:  
 i. Describe source(s), location(s), height of fixture(s), direction/aim, and proximity to nearest occupied structures:  
 BUILDING MOUNTED PARKING LOT LIGHTING  
 \_\_\_\_\_

ii. Will proposed action remove existing natural barriers that could act as a light barrier or screen?  Yes  No  
 Describe: \_\_\_\_\_  
 \_\_\_\_\_

---

o. Does the proposed action have the potential to produce odors for more than one hour per day?  Yes  No  
 If Yes, describe possible sources, potential frequency and duration of odor emissions, and proximity to nearest occupied structures:  
 \_\_\_\_\_  
 \_\_\_\_\_

---

p. Will the proposed action include any bulk storage of petroleum (combined capacity of over 1,100 gallons) or chemical products 185 gallons in above ground storage or any amount in underground storage?  Yes  No  
 If Yes:  
 i. Product(s) to be stored \_\_\_\_\_  
 ii. Volume(s) \_\_\_\_\_ per unit time \_\_\_\_\_ (e.g., month, year)  
 iii. Generally, describe the proposed storage facilities:  
 \_\_\_\_\_  
 \_\_\_\_\_

---

q. Will the proposed action (commercial, industrial and recreational projects only) use pesticides (i.e., herbicides, insecticides) during construction or operation?  Yes  No  
 If Yes:  
 i. Describe proposed treatment(s):  
 \_\_\_\_\_  
 \_\_\_\_\_  
 \_\_\_\_\_

ii. Will the proposed action use Integrated Pest Management Practices?  Yes  No

---

r. Will the proposed action (commercial or industrial projects only) involve or require the management or disposal of solid waste (excluding hazardous materials)?  Yes  No  
 If Yes:  
 i. Describe any solid waste(s) to be generated during construction or operation of the facility:  
 • Construction: \_\_\_\_\_ tons per \_\_\_\_\_ (unit of time)  
 • Operation : \_\_\_\_\_ tons per \_\_\_\_\_ (unit of time)  
 ii. Describe any proposals for on-site minimization, recycling or reuse of materials to avoid disposal as solid waste:  
 • Construction: \_\_\_\_\_  
 \_\_\_\_\_  
 • Operation: \_\_\_\_\_  
 \_\_\_\_\_  
 iii. Proposed disposal methods/facilities for solid waste generated on-site:  
 • Construction: \_\_\_\_\_  
 \_\_\_\_\_  
 • Operation: \_\_\_\_\_  
 \_\_\_\_\_

s. Does the proposed action include construction or modification of a solid waste management facility?  Yes  No

If Yes:

- i. Type of management or handling of waste proposed for the site (e.g., recycling or transfer station, composting, landfill, or other disposal activities): \_\_\_\_\_
- ii. Anticipated rate of disposal/processing:
  - \_\_\_\_\_ Tons/month, if transfer or other non-combustion/thermal treatment, or
  - \_\_\_\_\_ Tons/hour, if combustion or thermal treatment
- iii. If landfill, anticipated site life: \_\_\_\_\_ years

t. Will the proposed action at the site involve the commercial generation, treatment, storage, or disposal of hazardous waste?  Yes  No

If Yes:

- i. Name(s) of all hazardous wastes or constituents to be generated, handled or managed at facility: \_\_\_\_\_
- ii. Generally describe processes or activities involving hazardous wastes or constituents: \_\_\_\_\_
- iii. Specify amount to be handled or generated \_\_\_\_\_ tons/month
- iv. Describe any proposals for on-site minimization, recycling or reuse of hazardous constituents: \_\_\_\_\_
- v. Will any hazardous wastes be disposed at an existing offsite hazardous waste facility?  Yes  No

If Yes: provide name and location of facility: \_\_\_\_\_

If No: describe proposed management of any hazardous wastes which will not be sent to a hazardous waste facility: \_\_\_\_\_

**E. Site and Setting of Proposed Action**

**E.1. Land uses on and surrounding the project site**

a. Existing land uses.

i. Check all uses that occur on, adjoining and near the project site.

- Urban  Industrial  Commercial  Residential (suburban)  Rural (non-farm)
- Forest  Agriculture  Aquatic  Other (specify): \_\_\_\_\_

ii. If mix of uses, generally describe: \_\_\_\_\_

b. Land uses and covertypes on the project site.

Land use or Covertype	Current Acreage	Acreage After Project Completion	Change (Acres +/-)
• Roads, buildings, and other paved or impervious surfaces			
• Forested			
• Meadows, grasslands or brushlands (non-agricultural, including abandoned agricultural)			
• Agricultural (includes active orchards, field, greenhouse etc.)			
• Surface water features (lakes, ponds, streams, rivers, etc.)			
• Wetlands (freshwater or tidal)			
• Non-vegetated (bare rock, earth or fill)			
• Other Describe: _____			



c. Is the project site presently used by members of the community for public recreation?  Yes  No  
i. If Yes: explain: \_\_\_\_\_

d. Are there any facilities serving children, the elderly, people with disabilities (e.g., schools, hospitals, licensed day care centers, or group homes) within 1500 feet of the project site?  Yes  No  
If Yes,  
i. Identify Facilities: \_\_\_\_\_

e. Does the project site contain an existing dam?  Yes  No  
If Yes:  
i. Dimensions of the dam and impoundment:  
• Dam height: \_\_\_\_\_ feet  
• Dam length: \_\_\_\_\_ feet  
• Surface area: \_\_\_\_\_ acres  
• Volume impounded: \_\_\_\_\_ gallons OR acre-feet  
ii. Dam's existing hazard classification: \_\_\_\_\_  
iii. Provide date and summarize results of last inspection: \_\_\_\_\_

f. Has the project site ever been used as a municipal, commercial or industrial solid waste management facility, or does the project site adjoin property which is now, or was at one time, used as a solid waste management facility?  Yes  No  
If Yes:  
i. Has the facility been formally closed?  Yes  No  
• If yes, cite sources/documentation: \_\_\_\_\_  
ii. Describe the location of the project site relative to the boundaries of the solid waste management facility: \_\_\_\_\_  
iii. Describe any development constraints due to the prior solid waste activities: \_\_\_\_\_

g. Have hazardous wastes been generated, treated and/or disposed of at the site, or does the project site adjoin property which is now or was at one time used to commercially treat, store and/or dispose of hazardous waste?  Yes  No  
If Yes:  
i. Describe waste(s) handled and waste management activities, including approximate time when activities occurred: \_\_\_\_\_

h. Potential contamination history. Has there been a reported spill at the proposed project site, or have any remedial actions been conducted at or adjacent to the proposed site?  Yes  No  
If Yes:  
i. Is any portion of the site listed on the NYSDEC Spills Incidents database or Environmental Site Remediation database? Check all that apply:  Yes  No  
 Yes – Spills Incidents database Provide DEC ID number(s): \_\_\_\_\_  
 Yes – Environmental Site Remediation database Provide DEC ID number(s): \_\_\_\_\_  
 Neither database  
ii. If site has been subject of RCRA corrective activities, describe control measures: \_\_\_\_\_  
iii. Is the project within 2000 feet of any site in the NYSDEC Environmental Site Remediation database?  Yes  No  
If yes, provide DEC ID number(s): \_\_\_\_\_  
iv. If yes to (i), (ii) or (iii) above, describe current status of site(s): \_\_\_\_\_

v. Is the project site subject to an institutional control limiting property uses?  Yes  No

- If yes, DEC site ID number: \_\_\_\_\_
- Describe the type of institutional control (e.g., deed restriction or easement): \_\_\_\_\_
- Describe any use limitations: \_\_\_\_\_
- Describe any engineering controls: \_\_\_\_\_
- Will the project affect the institutional or engineering controls in place?  Yes  No
- Explain: \_\_\_\_\_

**E.2. Natural Resources On or Near Project Site**

a. What is the average depth to bedrock on the project site? \_\_\_\_\_ 6+ feet

b. Are there bedrock outcroppings on the project site?  Yes  No  
 If Yes, what proportion of the site is comprised of bedrock outcroppings? \_\_\_\_\_ %

c. Predominant soil type(s) present on project site: \_\_\_\_\_ %  
 \_\_\_\_\_ %  
 \_\_\_\_\_ %

d. What is the average depth to the water table on the project site? Average: \_\_\_\_\_ feet

e. Drainage status of project site soils:  Well Drained: \_\_\_\_\_ % of site  
 Moderately Well Drained: \_\_\_\_\_ % of site  
 Poorly Drained \_\_\_\_\_ % of site

f. Approximate proportion of proposed action site with slopes:  0-10%: \_\_\_\_\_ % of site  
 10-15%: \_\_\_\_\_ % of site  
 15% or greater: \_\_\_\_\_ % of site

g. Are there any unique geologic features on the project site?  Yes  No  
 If Yes, describe: \_\_\_\_\_

h. Surface water features.

i. Does any portion of the project site contain wetlands or other waterbodies (including streams, rivers, ponds or lakes)?  Yes  No

ii. Do any wetlands or other waterbodies adjoin the project site?  Yes  No

If Yes to either *i* or *ii*, continue. If No, skip to E.2.i.

iii. Are any of the wetlands or waterbodies within or adjoining the project site regulated by any federal, state or local agency?  Yes  No

iv. For each identified regulated wetland and waterbody on the project site, provide the following information:

- Streams: Name 862-226, 862-227 Classification C
- Lakes or Ponds: Name \_\_\_\_\_ Classification \_\_\_\_\_
- Wetlands: Name Federal Waters, NYS Wetland, Federal Waters, Fe... Approximate Size NYS Wetland (in a...
- Wetland No. (if regulated by DEC) NB-22

v. Are any of the above water bodies listed in the most recent compilation of NYS water quality-impaired waterbodies?  Yes  No

If yes, name of impaired water body/bodies and basis for listing as impaired: \_\_\_\_\_

i. Is the project site in a designated Floodway?  Yes  No

j. Is the project site in the 100-year Floodplain?  Yes  No

k. Is the project site in the 500-year Floodplain?  Yes  No

l. Is the project site located over, or immediately adjoining, a primary, principal or sole source aquifer?  Yes  No

If Yes:

i. Name of aquifer: \_\_\_\_\_

m. Identify the predominant wildlife species that occupy or use the project site: \_\_\_\_\_  
 DEER \_\_\_\_\_  
 \_\_\_\_\_

n. Does the project site contain a designated significant natural community?  Yes  No  
 If Yes:  
 i. Describe the habitat/community (composition, function, and basis for designation): \_\_\_\_\_  
 ii. Source(s) of description or evaluation: \_\_\_\_\_  
 iii. Extent of community/habitat:  
 • Currently: \_\_\_\_\_ acres  
 • Following completion of project as proposed: \_\_\_\_\_ acres  
 • Gain or loss (indicate + or -): \_\_\_\_\_ acres

o. Does project site contain any species of plant or animal that is listed by the federal government or NYS as endangered or threatened, or does it contain any areas identified as habitat for an endangered or threatened species?  Yes  No  
 If Yes:  
 i. Species and listing (endangered or threatened): \_\_\_\_\_  
 Indiana Bat

p. Does the project site contain any species of plant or animal that is listed by NYS as rare, or as a species of special concern?  Yes  No  
 If Yes:  
 i. Species and listing: \_\_\_\_\_

q. Is the project site or adjoining area currently used for hunting, trapping, fishing or shell fishing?  Yes  No  
 If yes, give a brief description of how the proposed action may affect that use: \_\_\_\_\_

**E.3. Designated Public Resources On or Near Project Site**

a. Is the project site, or any portion of it, located in a designated agricultural district certified pursuant to Agriculture and Markets Law, Article 25-AA, Section 303 and 304?  Yes  No  
 If Yes, provide county plus district name/number: \_\_\_\_\_

b. Are agricultural lands consisting of highly productive soils present?  Yes  No  
 i. If Yes: acreage(s) on project site? \_\_\_\_\_  
 ii. Source(s) of soil rating(s): \_\_\_\_\_

c. Does the project site contain all or part of, or is it substantially contiguous to, a registered National Natural Landmark?  Yes  No  
 If Yes:  
 i. Nature of the natural landmark:  Biological Community  Geological Feature  
 ii. Provide brief description of landmark, including values behind designation and approximate size/extent: \_\_\_\_\_

d. Is the project site located in or does it adjoin a state listed Critical Environmental Area?  Yes  No  
 If Yes:  
 i. CEA name: \_\_\_\_\_  
 ii. Basis for designation: \_\_\_\_\_  
 iii. Designating agency and date: \_\_\_\_\_

e. Does the project site contain, or is it substantially contiguous to, a building, archaeological site, or district which is listed on the National or State Register of Historic Places, or that has been determined by the Commissioner of the NYS Office of Parks, Recreation and Historic Preservation to be eligible for listing on the State Register of Historic Places?	<input type="checkbox"/> Yes <input checked="" type="checkbox"/> No
If Yes:	
<i>i.</i> Nature of historic/archaeological resource: <input type="checkbox"/> Archaeological Site <input type="checkbox"/> Historic Building or District	
<i>ii.</i> Name: _____	
<i>iii.</i> Brief description of attributes on which listing is based: _____	
f. Is the project site, or any portion of it, located in or adjacent to an area designated as sensitive for archaeological sites on the NY State Historic Preservation Office (SHPO) archaeological site inventory?	<input checked="" type="checkbox"/> Yes <input type="checkbox"/> No
g. Have additional archaeological or historic site(s) or resources been identified on the project site?	
If Yes:	
<i>i.</i> Describe possible resource(s): _____	
<i>ii.</i> Basis for identification: _____	
h. Is the project site within five miles of any officially designated and publicly accessible federal, state, or local scenic or aesthetic resource?	<input type="checkbox"/> Yes <input type="checkbox"/> No
If Yes:	
<i>i.</i> Identify resource: _____	
<i>ii.</i> Nature of, or basis for, designation (e.g., established highway overlook, state or local park, state historic trail or scenic byway, etc.): _____	
<i>iii.</i> Distance between project and resource: _____ miles.	
i. Is the project site located within a designated river corridor under the Wild, Scenic and Recreational Rivers Program 6 NYCRR 666?	<input type="checkbox"/> Yes <input checked="" type="checkbox"/> No
If Yes:	
<i>i.</i> Identify the name of the river and its designation: _____	
<i>ii.</i> Is the activity consistent with development restrictions contained in 6NYCRR Part 666?	
<input type="checkbox"/> Yes <input type="checkbox"/> No	

**F. Additional Information**

Attach any additional information which may be needed to clarify your project.

If you have identified any adverse impacts which could be associated with your proposal, please describe those impacts plus any measures which you propose to avoid or minimize them.

**G. Verification**

I certify that the information provided is true to the best of my knowledge.

Applicant/Sponsor Name CHARLES T BROWN, PE Date 9-16-2021

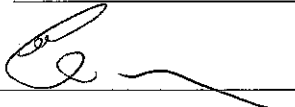
Signature  Title PROJECT ENGINEER

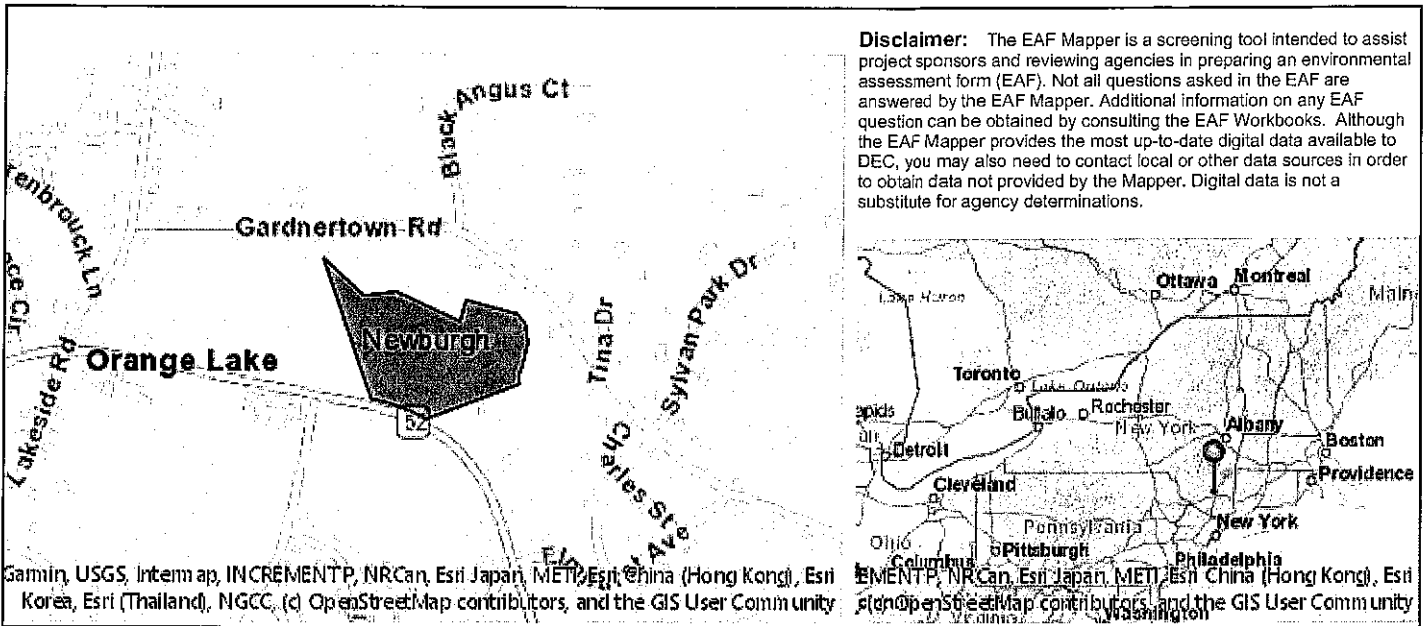

B.i.i [Coastal or Waterfront Area]	No
B.i.ii [Local Waterfront Revitalization Area]	No
C.2.b. [Special Planning District]	Digital mapping data are not available or are incomplete. Refer to EAF Workbook.
E.1.h [DEC Spills or Remediation Site - Potential Contamination History]	Digital mapping data are not available or are incomplete. Refer to EAF Workbook.
E.1.h.i [DEC Spills or Remediation Site - Listed]	Digital mapping data are not available or are incomplete. Refer to EAF Workbook.
E.1.h.i [DEC Spills or Remediation Site - Environmental Site Remediation Database]	Digital mapping data are not available or are incomplete. Refer to EAF Workbook.
E.1.h.iii [Within 2,000' of DEC Remediation Site]	No
E.2.g [Unique Geologic Features]	No
E.2.h.i [Surface Water Features]	Yes
E.2.h.ii [Surface Water Features]	Yes
E.2.h.iii [Surface Water Features]	Yes - Digital mapping information on local and federal wetlands and waterbodies is known to be incomplete. Refer to EAF Workbook.
E.2.h.iv [Surface Water Features - Stream Name]	862-226, 862-227
E.2.h.iv [Surface Water Features - Stream Classification]	C
E.2.h.iv [Surface Water Features - Wetlands Name]	Federal Waters, NYS Wetland
E.2.h.iv [Surface Water Features - Wetlands Size]	NYS Wetland (in acres):28.1
E.2.h.iv [Surface Water Features - DEC Wetlands Number]	NB-22
E.2.h.v [Impaired Water Bodies]	No

E.2.i. [Floodway]	Yes
E.2.j. [100 Year Floodplain]	Yes
E.2.k. [500 Year Floodplain]	Yes
E.2.l. [Aquifers]	No
E.2.n. [Natural Communities]	No
E.2.o. [Endangered or Threatened Species]	Yes
E.2.o. [Endangered or Threatened Species - Name]	Indiana Bat
E.2.p. [Rare Plants or Animals]	No
E.3.a. [Agricultural District]	No
E.3.c. [National Natural Landmark]	No
E.3.d. [Critical Environmental Area]	No
E.3.e. [National or State Register of Historic Places or State Eligible Sites]	Digital mapping data are not available or are incomplete. Refer to EAF Workbook.
E.3.f. [Archeological Sites]	Yes
E.3.i. [Designated River Corridor]	No

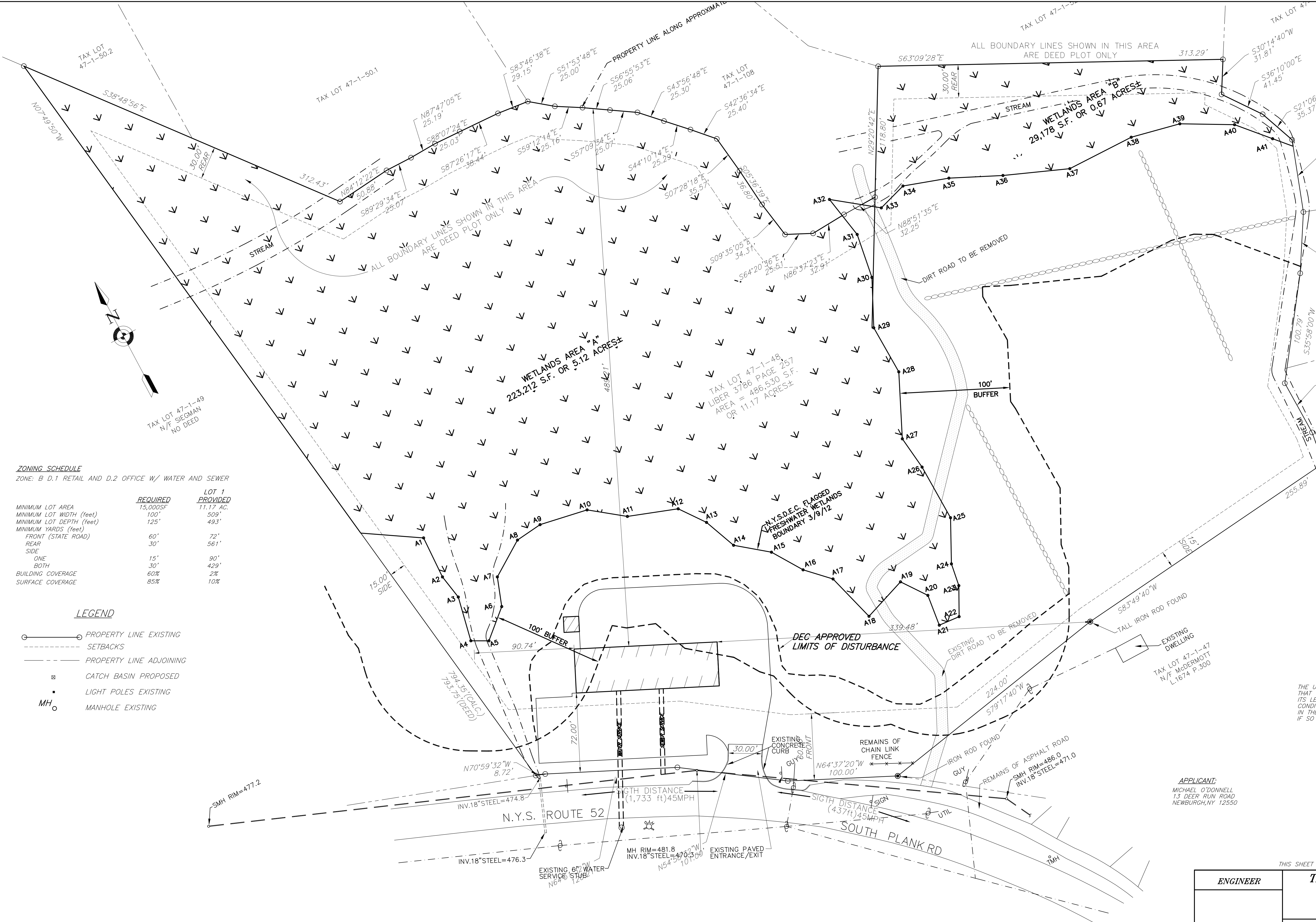
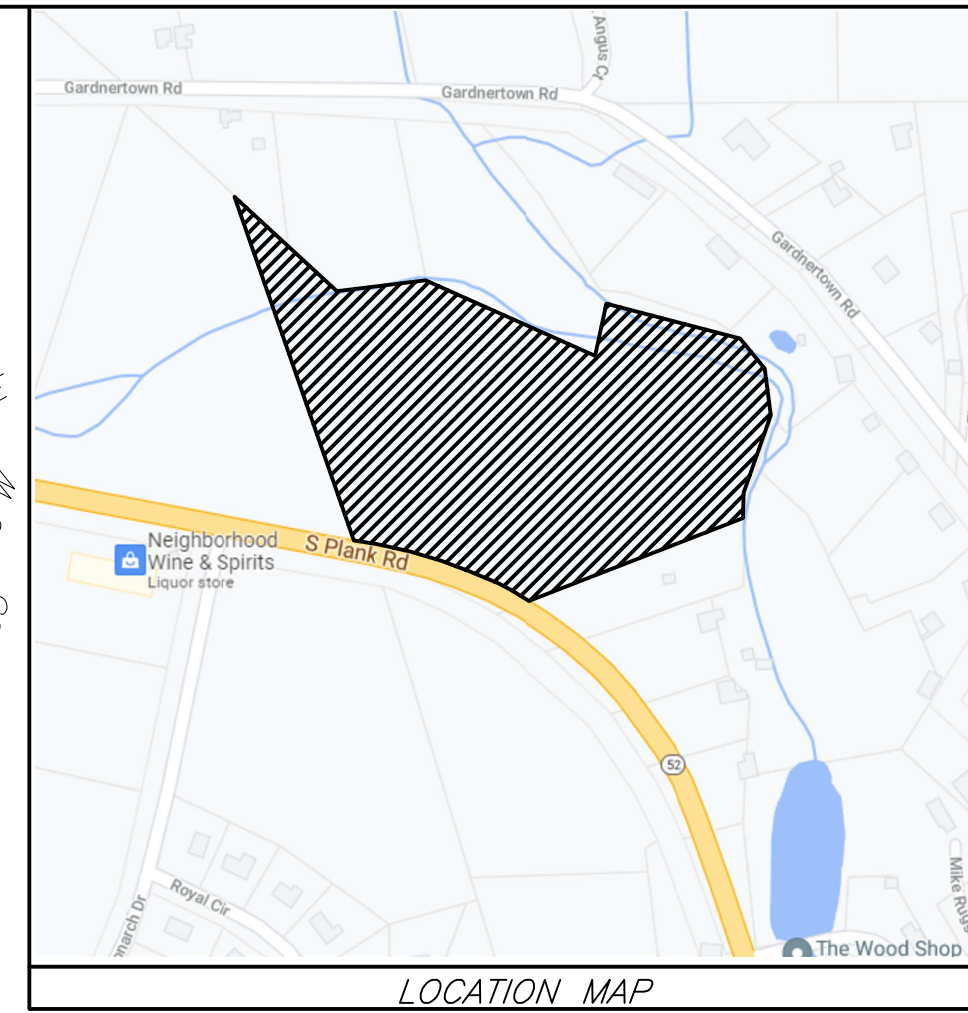

**ZONING SCHEDULE**  
 ZONE: B D.1 RETAIL AND D.2 OFFICE W/ WATER AND SEWER

	REQUIRED	LOT 1 PROVIDED
MINIMUM LOT AREA	15,000SF	11.17 AC.
MINIMUM LOT WIDTH (feet)	100'	509'
MINIMUM LOT DEPTH (feet)	125'	493'
MINIMUM YARDS (feet)		
FRONT (STATE ROAD)	60'	72'
REAR	30'	561'
SIDE		
ONE	15'	90'
BOTH	30'	429'
BUILDING COVERAGE	60%	2%
SURFACE COVERAGE	85%	10%

- LEGEND**
- PROPERTY LINE EXISTING
  - SETBACKS
  - PROPERTY LINE ADJOINING
  - ⊗ CATCH BASIN PROPOSED
  - LIGHT POLES EXISTING
  - MH ○ MANHOLE EXISTING

**SURVEYOR'S CERTIFICATION:**  
 I HEREBY CERTIFY TO THE PARTIES OF INTEREST LISTED BELOW THAT THIS MAP SHOWS THE RESULTS OF AN ACTUAL SURVEY COMPLETED IN THE FIELD IN...  
 SIGNATURE \_\_\_\_\_ DARREN STRIDIRON PLS

**RECORD OWNER'S CONSENT NOTE:**  
 THE UNDERSIGNED OWNERS OF THE PROPERTY HEREON STATE THAT THEY ARE FAMILIAR WITH THIS PLAN, ITS CONTENTS AND ITS LEGENDS AND HEREBY CONSENT TO ALL SAID TERMS AND CONDITIONS AS STATED HEREON AND TO THE FILING OF THIS PLAN IN THE OFFICE OF THE CLERK OF THE COUNTY OF ORANGE, IF SO REQUIRED.

RECORD OWNER'S SIGNATURE MICHAEL O'DONNELL  
 2 PLANK ROAD  
 NEWBURGH, NY 12550

RECORD OWNER'S SIGNATURE SHERRI O'DONNELL  
 2 PLANK ROAD  
 NEWBURGH, NY 12550

**APPLICANT:**  
 MICHAEL O'DONNELL  
 13 DEER RUN ROAD  
 NEWBURGH, NY 12550

NEWBURGH TOWN PROJECT #2022-03  
 THIS SHEET IS INVALID AND VOID UNLESS ACCOMPANIED BY REMAINING SHEETS IN SET.

<b>ENGINEER</b>	<b>TALCOTT ENGINEERING DESIGN PLLC</b>			
	1 GARDINERTOWN ROAD NEWBURGH, NY 12550 (845)-569-8400 (FAX)(845)-569-4583 TALCOTTDESIGN12@GMAIL.COM			
<b>LOT LAYOUT</b>				
<b>COMMERCIAL SITE PLAN</b>				
<b>O'DONNELL</b>				
<b>RT 52, SBL: 47-1-48</b>				
<b>TOWN OF NEWBURGH, ORANGE COUNTY, NY</b>				
DATE	SCALE	JOB NUMBER	SHEET NUMBER	
12/21/2021	1"=40'	20003-MDL	1 OF 3	

**REVISIONS**

REV.:	DATE:	BY:	DESCRIPTION:

**CALL BEFORE YOU DIG... IT'S THE LAW**  
 WHETHER YOU'RE LAYING A FOUNDATION FOR A BUILDING OR PLANTING A TREE, YOU MUST FIRST CHECK FOR THE EXISTENCE OF UNDERGROUND UTILITY LINES AND CABLES. IF YOU OR YOUR CONTRACTOR DISRUPT ANY OF THESE LINES, THE RESULTS CAN BE DANGEROUS - AND COSTLY - TO EVERYONE. CALL BEFORE YOU DIG, TOLL FREE, 811

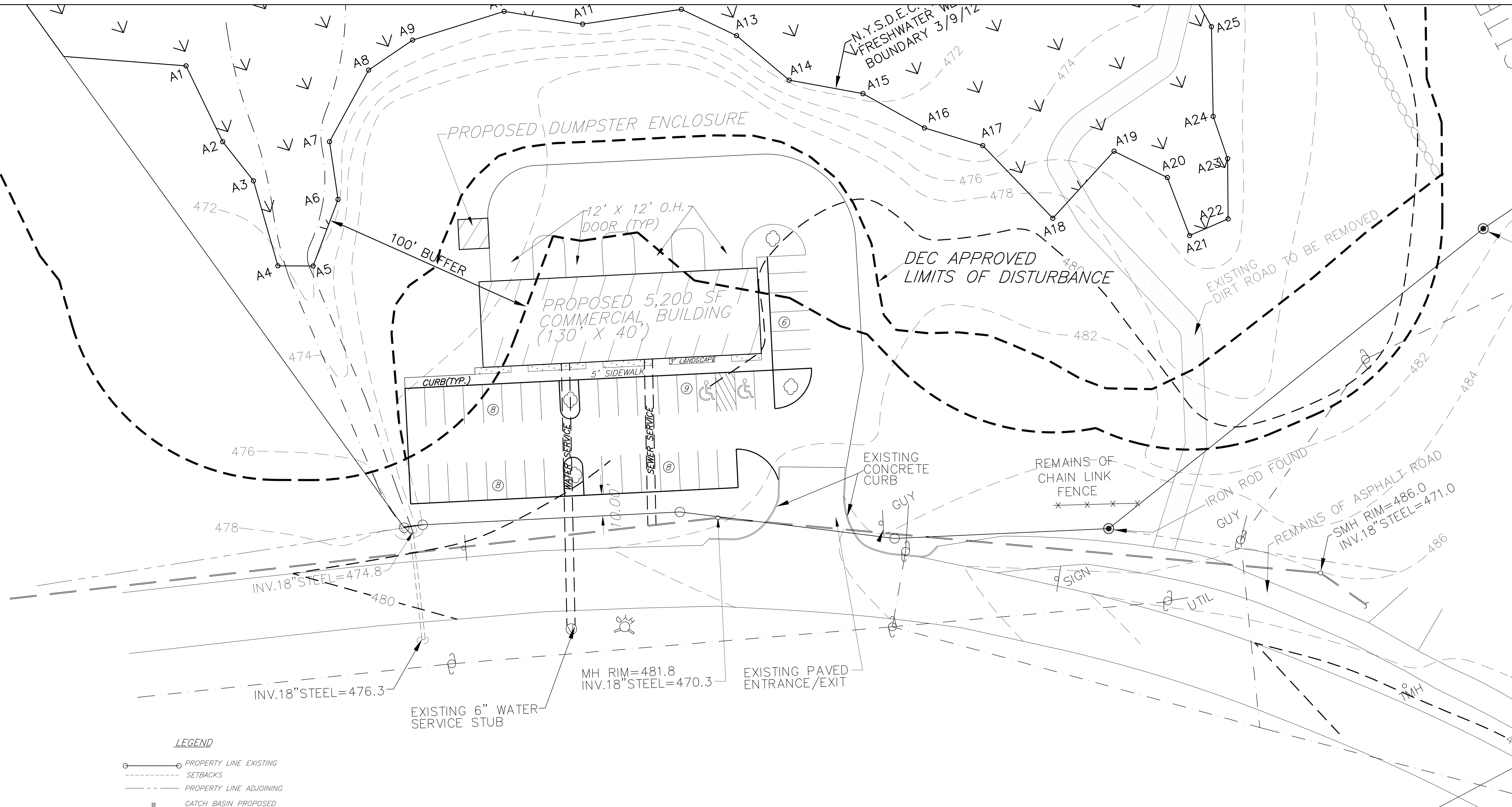

**LEGEND**

- PROPERTY LINE EXISTING
- SETBACKS
- PROPERTY LINE ADJOINING
- ⊗ CATCH BASIN PROPOSED
- LIGHT POLES EXISTING
- MH ○ MANHOLE EXISTING

**PROPOSED PARKING SCHEDULE**  
 OFFICE: 1/200sf. x 5,200 = 26 SPACES REQUIRED  
 RETAIL: 1/150sf. x 5,200sf. = 34 SPACES REQUIRED  
 TOTAL SPACES REQUIRED ON SITE = 34 INCLUDING 2 HANDICAPPED SPACES  
 1 OFF STREET LOADING SPACE REQUIRED (12' WIDE) 4 PROVIDED  
 39 SPACES PROVIDED

REVISIONS			
REV.	DATE	BY	DESCRIPTION

<b>ENGINEER</b>	NEWBURGH TOWN PROJECT #2022-03		
	<b>TALCOTT ENGINEERING DESIGN PLLC</b>		
	1 GARDINERTOWN ROAD NEWBURGH, NY 12550 (845)-569-8400 (FAX)(845)-569-4583 TALCOTTDESIGN12@GMAIL.COM		
	<b>BUILDING &amp; PARKING LAYOUT</b>		
<b>COMMERCIAL SITE PLAN</b>			
<b>O'DONNELL</b>			
<b>RT 52, SBL: 47-1-48</b>			
<b>TOWN OF NEWBURGH, ORANGE COUNTY, NY</b>			
DATE 01/04/21	SCALE 1"=20'	JOB NUMBER 20003-MDL	SHEET NUMBER 2 OF 3



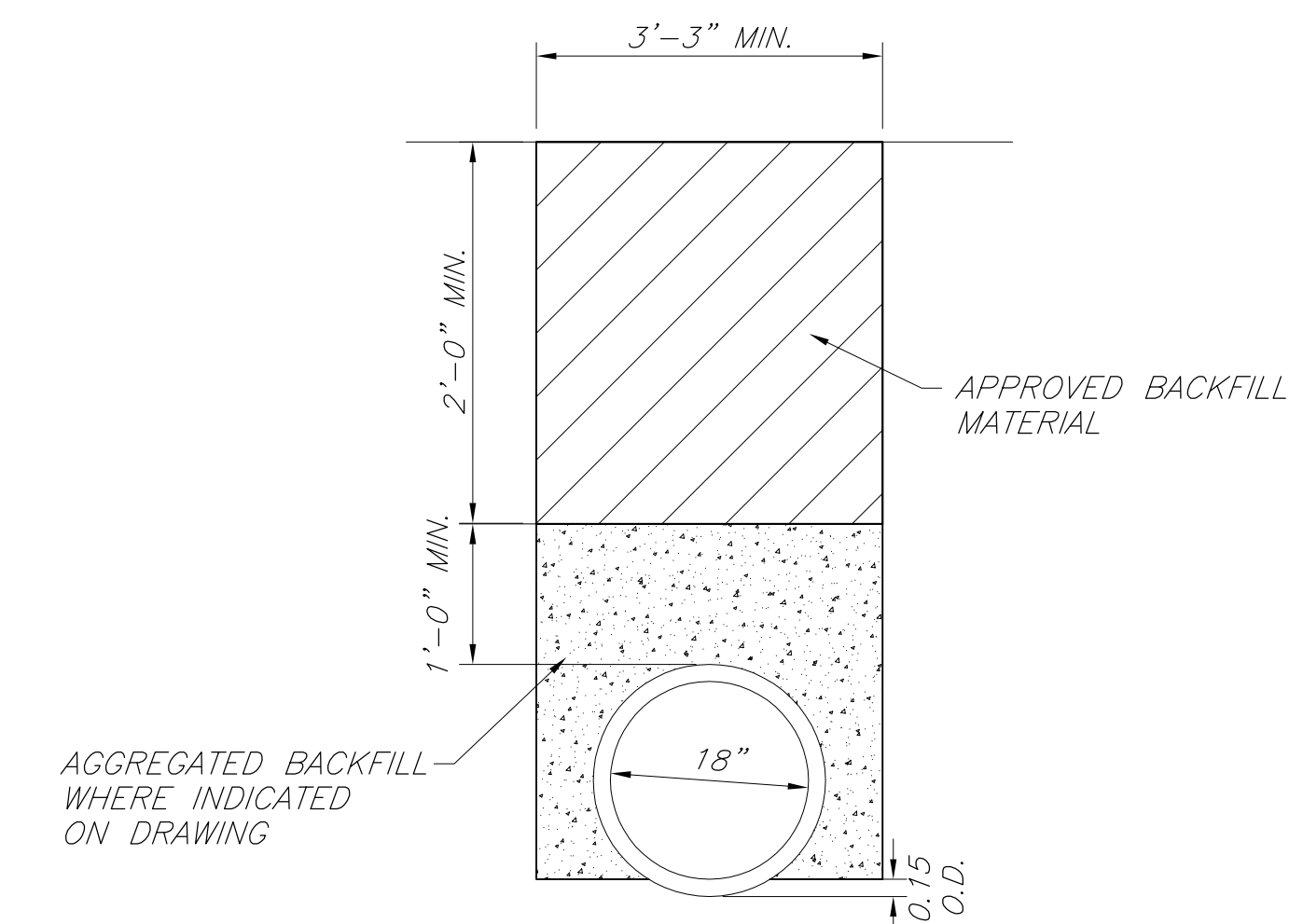
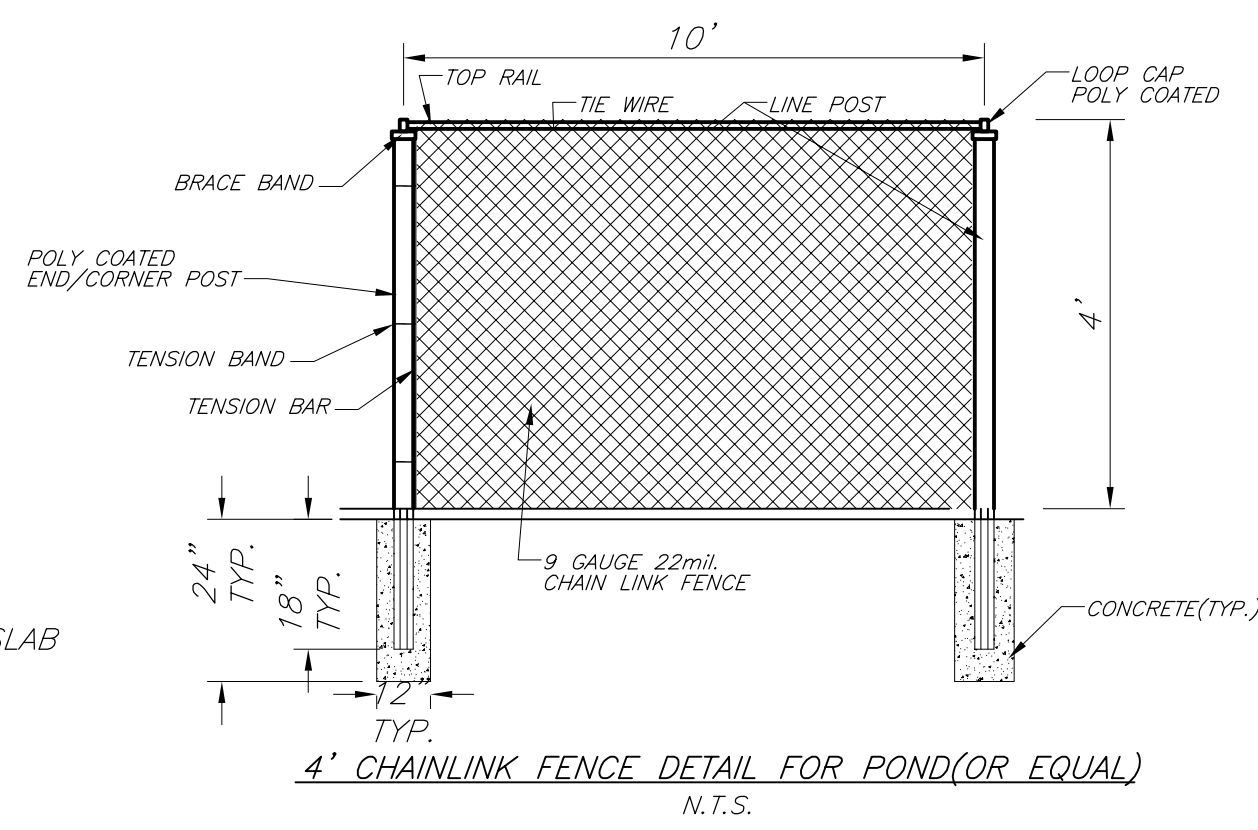
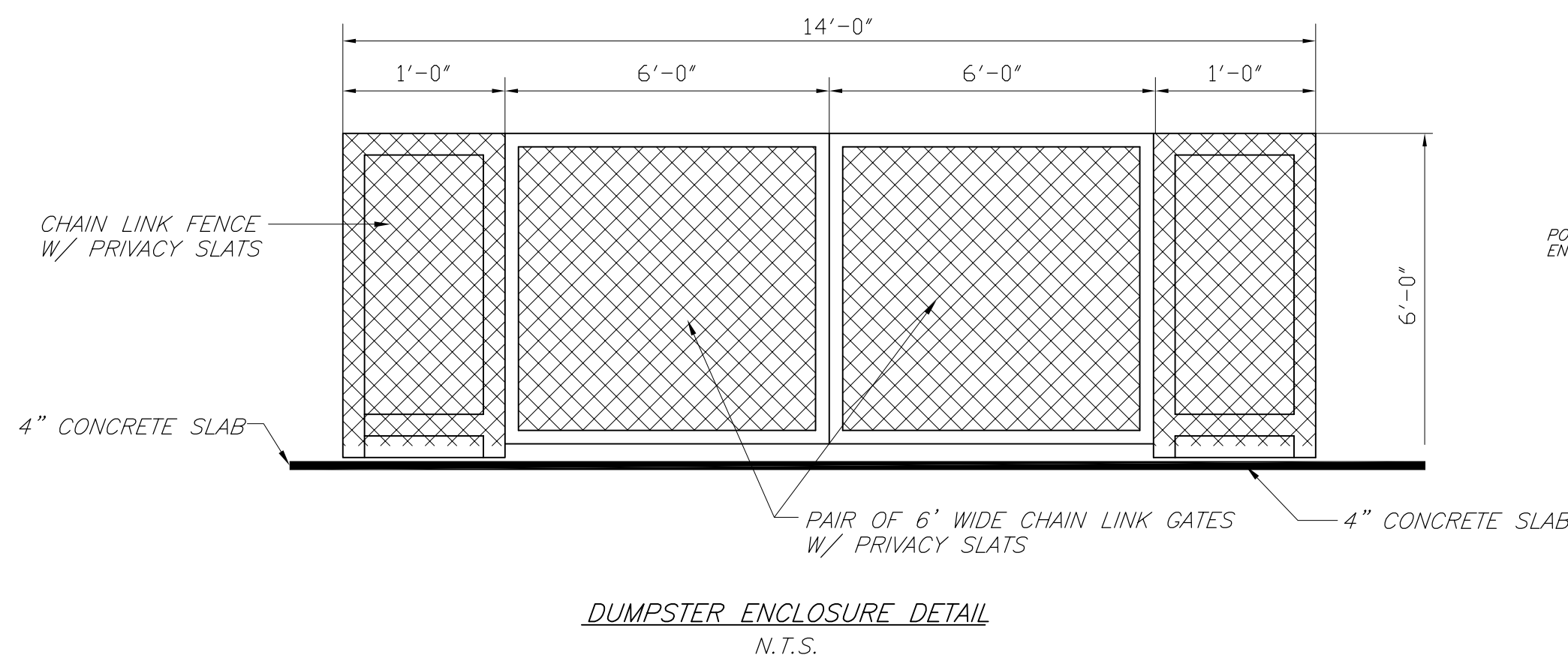

**NOTE:**  
1. FILL SECTION AREA MUST BE GRADED TO 2'-0" MIN. ABOVE TOP OF PIPE BEFORE EXCAVATING TRENCH.

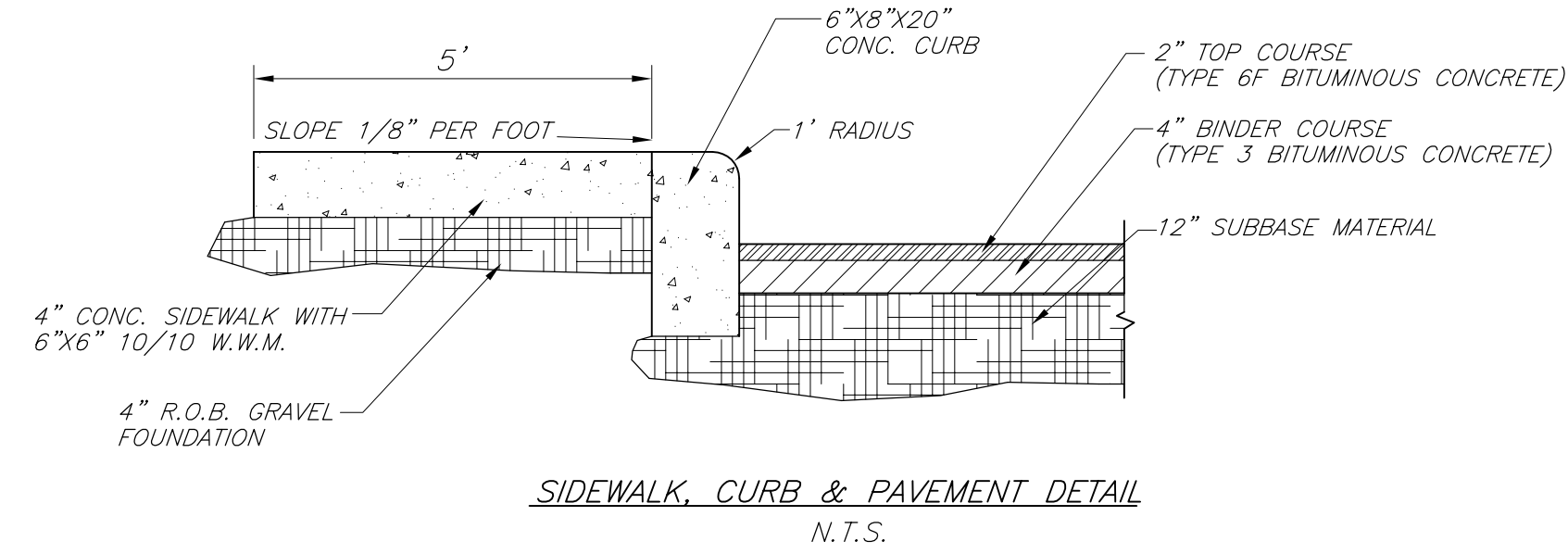
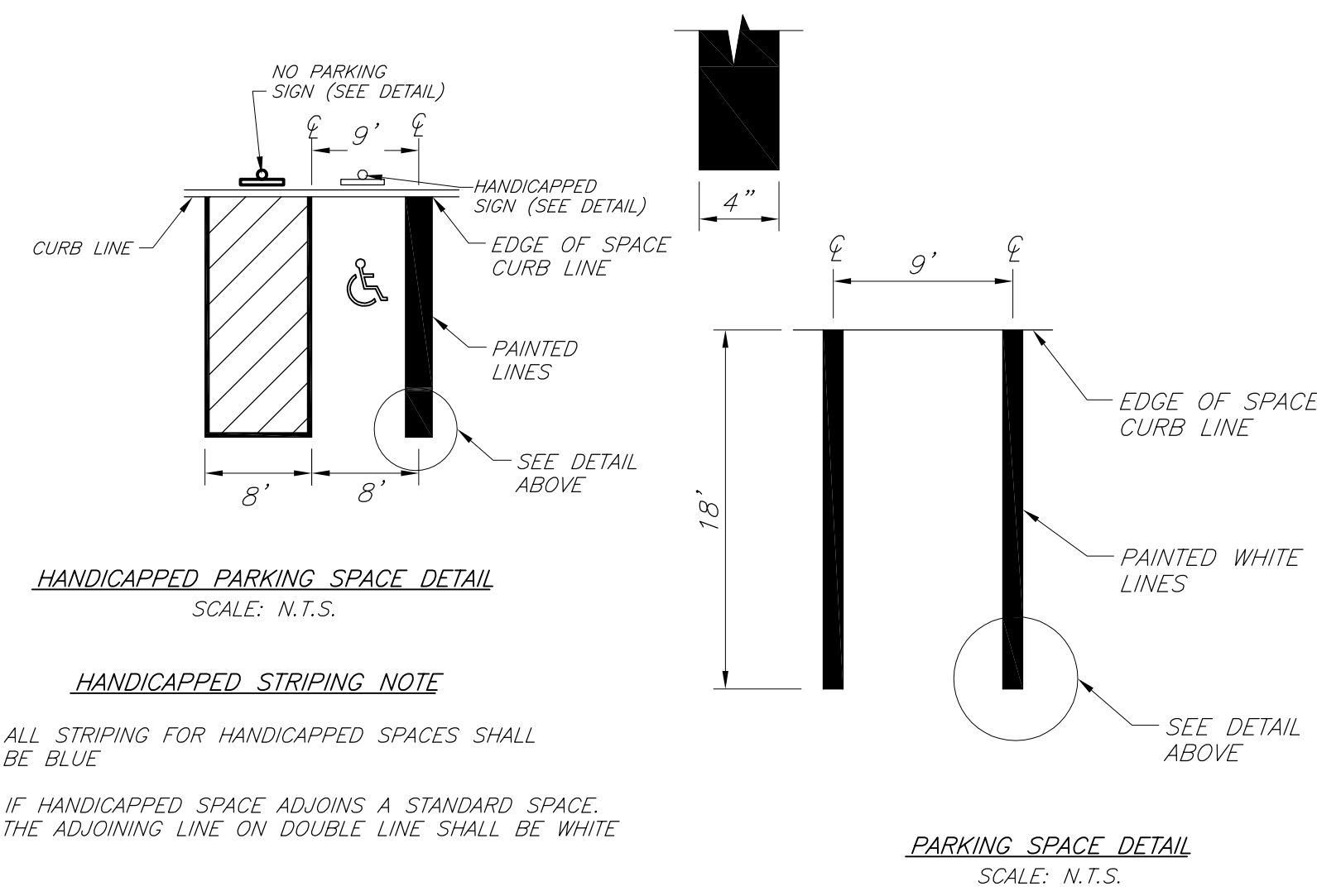

**SIDEWALK NOTE:**  
PROVIDE 1/4" PRE MOLDED EXPANSION JOINTS AT 20' INTERVALS.

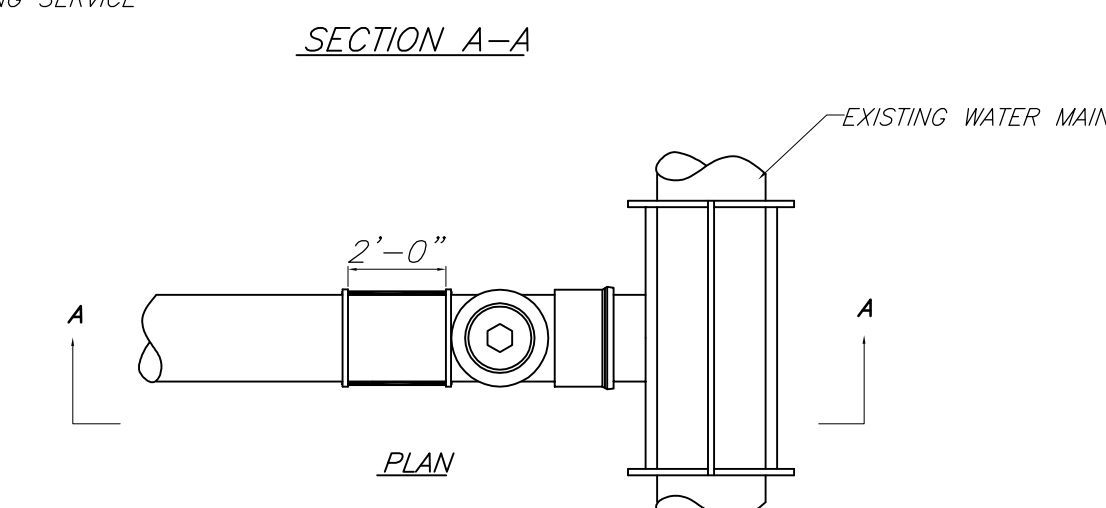
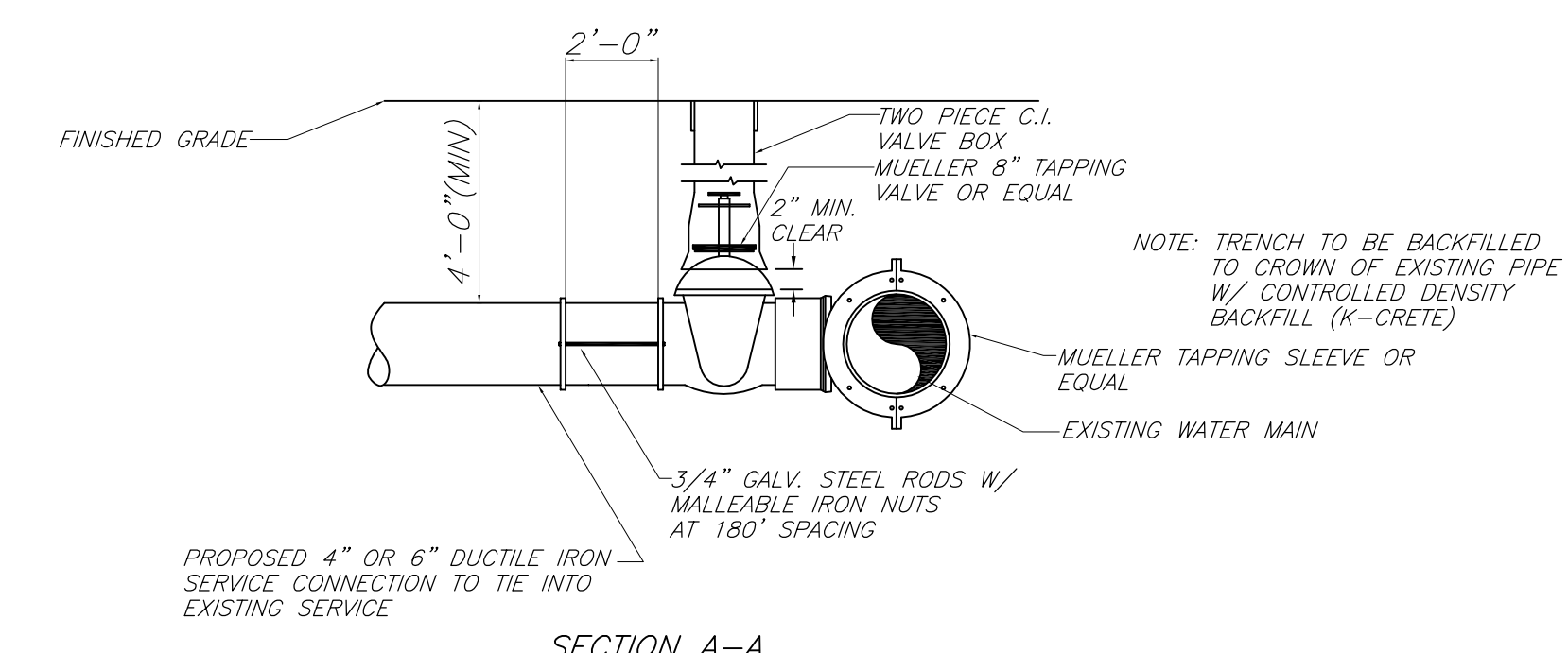
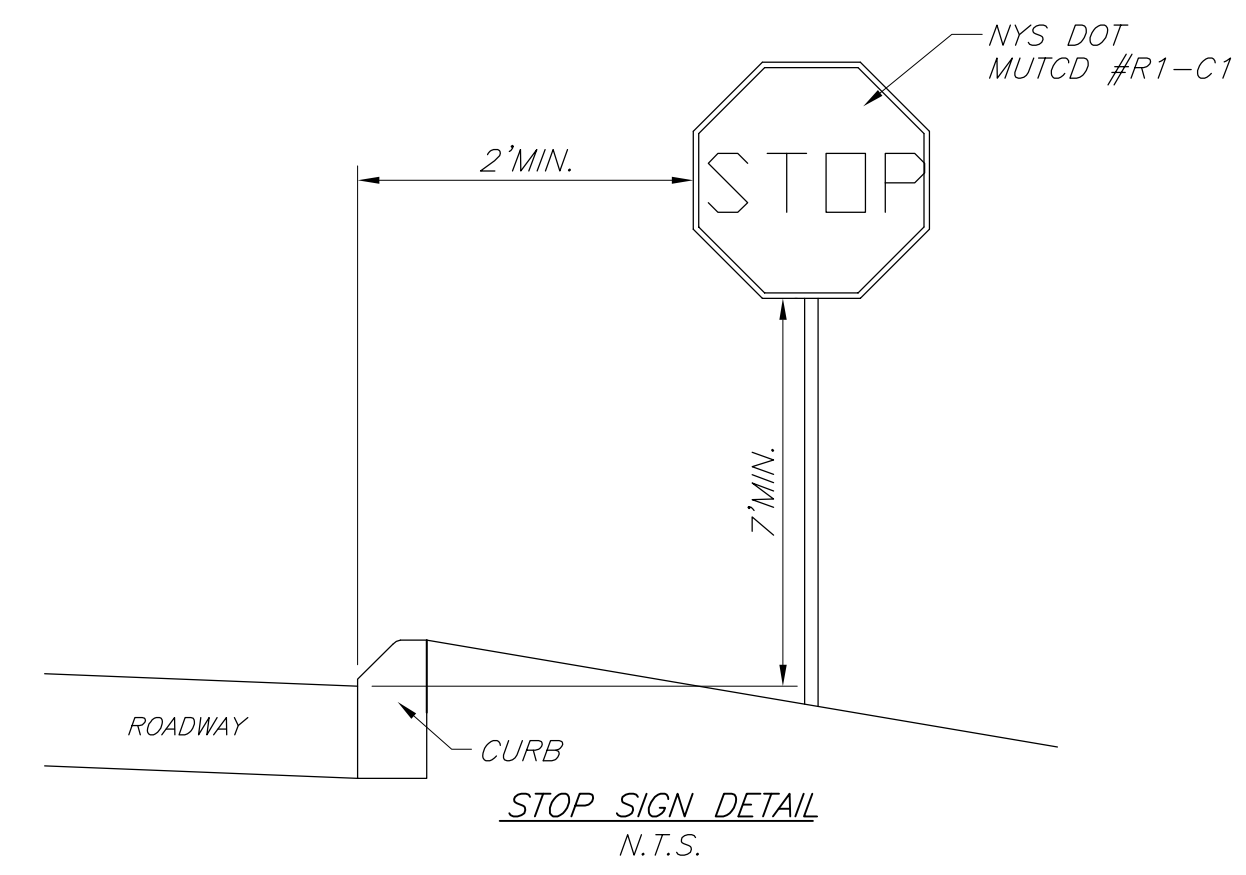

**WATER SERVICE CONNECTION DETAIL**  
N.T.S.

**TOWN OF NEWBURGH WATER SERVICE NOTES**

- "CONSTRUCTION OF POTABLE WATER UTILITIES AND CONNECTION TO THE T.O.N. WATER SYSTEM REQUIRES A PERMIT FROM THE T.O.N. WATER DEPARTMENT. ALL WORK AND MATERIALS SHALL CONFORM TO THE REQUIREMENTS OF THE NYSDOH AND THE T.O.N."
- ALL WATER SERVICE LINES FOUR (4) INCHES AND LARGER IN DIAMETER SHALL BE CEMENT LINED CLASS 52 DUCTILE IRON PIPE CONFORMING TO ANSI/AWWA C151/A21.51-91 FOR DUCTILE IRON PIPE. JOINTS SHALL BE EITHER PUSH-ON OR MECHANICAL JOINT AS REQUIRED.
- THRUST RESTRAINT OF THE PIPE SHALL BE THROUGH THE USE OF JOINT RESTRAINT. THRUST BLOCKS ARE NOT ACCEPTABLE. JOINT RESTRAINT SHALL BE THROUGH THE USE OF MECHANICAL JOINT PIPE WITH RETAINER GLANDS. ALL FITTINGS AND VALVES SHALL BE INSTALLED WITH RETAINER GLANDS FOR JOINT RESTRAINT. RETAINER GLANDS SHALL BE EBBA IRON MEGALUG SERIES 1100 OR APPROVED EQUAL. THE USE OF A MANUFACTURED RESTRAINED JOINT PIPE IS ACCEPTABLE WITH PRIOR APPROVAL OF THE WATER DEPARTMENT.
- ALL FITTINGS SHALL BE CAST IRON OR DUCTILE IRON, MECHANICAL JOINT, CLASS 250 AND CONFORM TO ANSI/AWWA C110/A21.10-87 FOR DUCTILE AND GRAY IRON FITTINGS OR ANSI/AWWA C153/A21.53-94 FOR DUCTILE IRON COMPACT FITTINGS.
- ALL VALVES 4 TO 12 INCHES SHALL BE RESILIENT WEDGE GATE VALVES CONFORMING TO ANSI/AWWA C509 SUCH AS MUELLER MODEL A-2360-23 OR APPROVED EQUAL. ALL GATE VALVES SHALL OPEN LEFT (COUNTERCLOCKWISE).
- TAPPING SLEEVE SHALL BE MECHANICAL JOINT SUCH AS MUELLER H-615 OR EQUAL. TAPPING VALVES 4 TO 12 INCHES SHALL BE RESILIENT WEDGE GATE VALVES CONFORMING TO ANSI/AWWA C509 SUCH AS MUELLER MODEL T-2360-19 OR APPROVED EQUAL. ALL TAPPING SLEEVES AND VALVES SHALL BE TESTED TO 150 PSI MINIMUM; TESTING OF THE TAPPING SLEEVE AND VALVE MUST BE WITNESSED AND ACCEPTED BY THE T.O.N. WATER DEPARTMENT PRIOR TO CUTTING INTO THE PIPE.
- ALL WATER SERVICE LINES TWO (2) INCHES IN DIAMETER AND SMALLER SHALL BE TYPE K COPPER TUBING. CORPORATION STOPS SHALL BE MUELLER H-15020 FOR 3/4 AND 1 INCH, MUELLER H-15003 OR B-25000 FOR 1 1/2 AND 2 INCH SIZES. CURB VALVES SHALL BE MUELLER H-1502-2 FOR 3/4 AND 1 INCH AND MUELLER B-25204 FOR 1 1/2 AND 2 INCH SIZES. CURB BOXES SHALL BE MUELLER H-10314 FOR 3/4 AND 1 INCH AND MUELLER H-10310 FOR 1 1/2 AND 2 INCH SIZES.
- ALL PIPE INSTALLATION SHALL BE SUBJECT TO INSPECTION BY THE T.O.N. WATER DEPARTMENT. THE CONTRACTOR SHALL BE RESPONSIBLE FOR COORDINATING ALL INSPECTIONS AS REQUIRED WITH THE T.O.N. WATER DEPARTMENT.
- THE WATER MAIN SHALL BE TESTED, DISINFECTED AND FLUSHED IN ACCORDANCE WITH THE T.O.N. REQUIREMENTS. ALL TESTING, DISINFECTION AND FLUSHING SHALL BE COORDINATED WITH THE T.O.N. WATER DEPARTMENT. PRIOR TO PUTTING THE WATER MAIN IN SERVICE SATISFACTORY SANITARY RESULTS FROM CERTIFIED LAB MUST BE SUBMITTED TO THE T.O.N. WATER DEPARTMENT. THE TEST SAMPLES MUST BE COLLECTED BY A REPRESENTATIVE OF THE TESTING LABORATORY AND WITNESSED BY THE WATER DEPARTMENT.

NEWBURGH TOWN PROJECT #2022-03

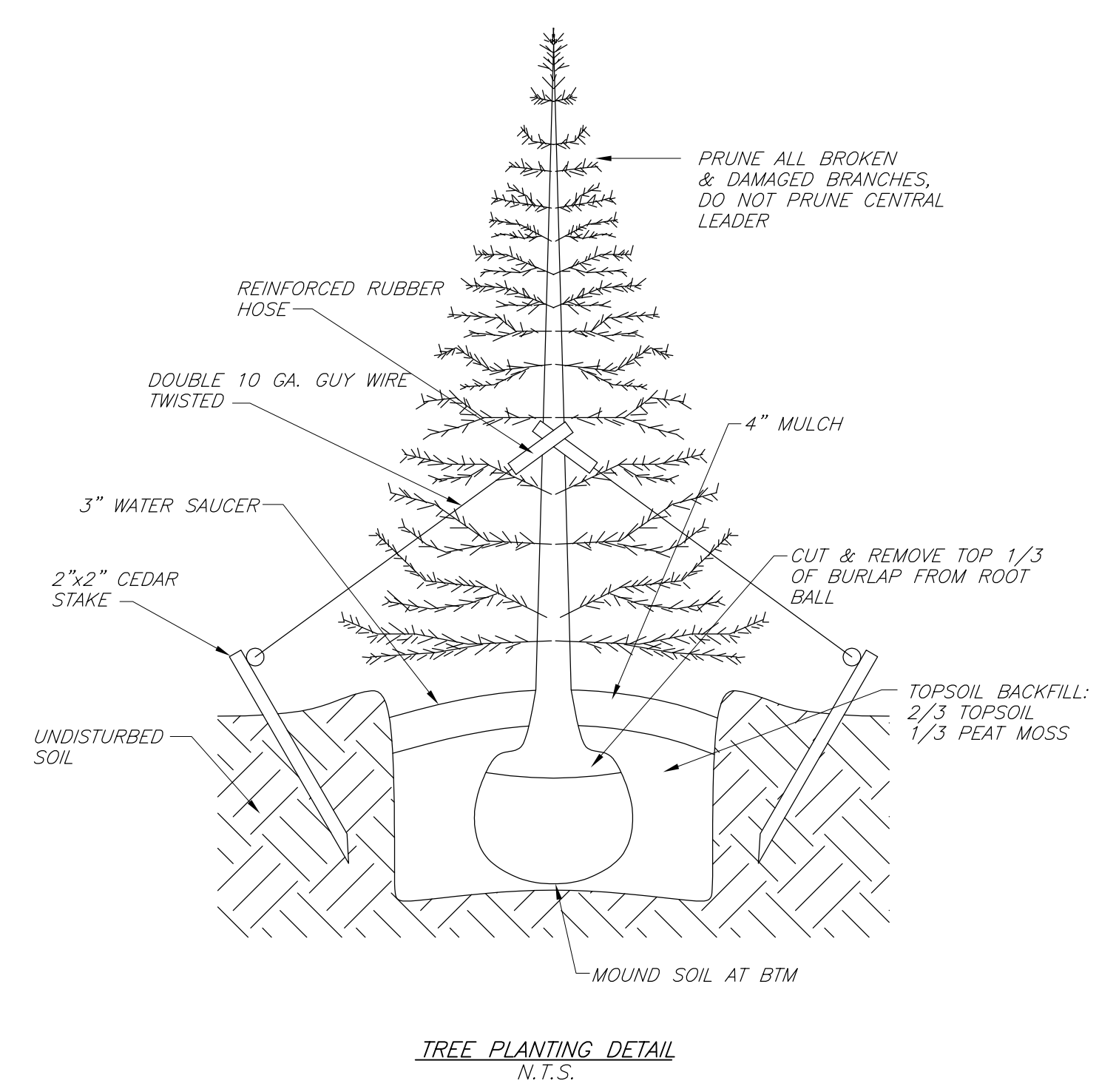
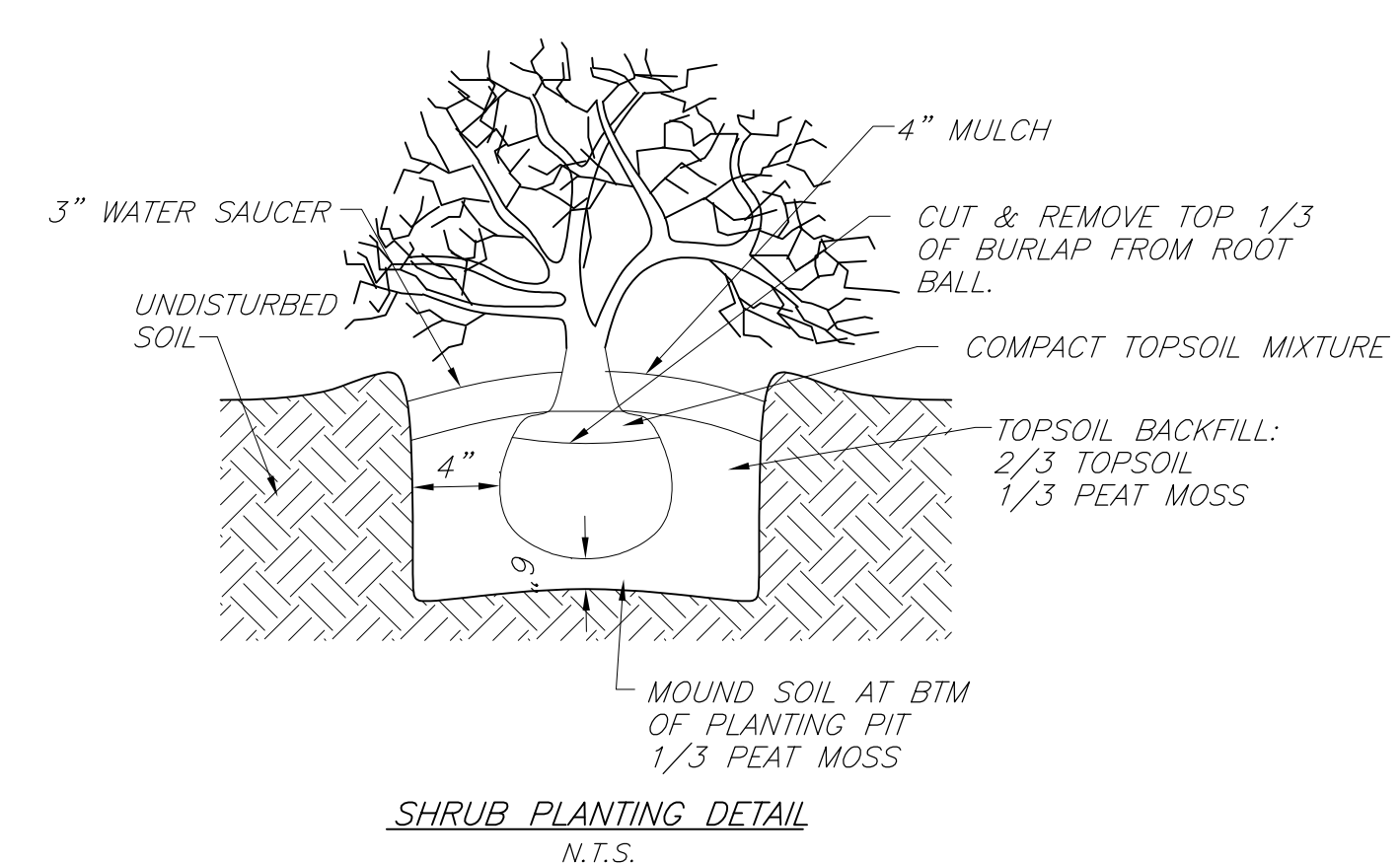
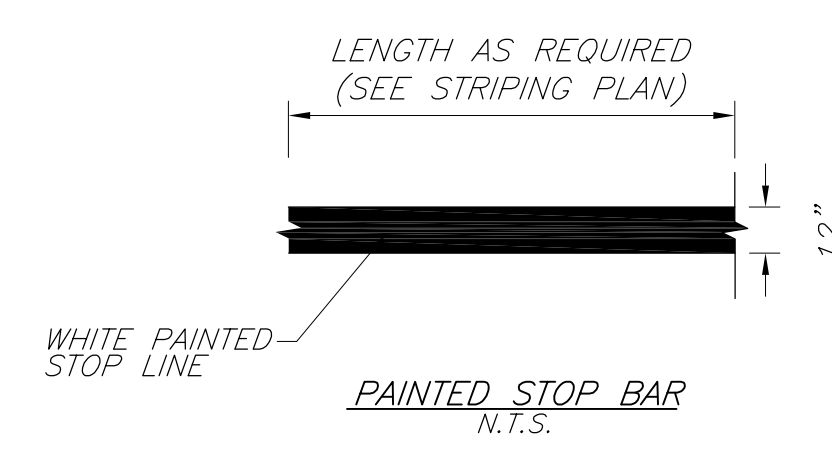
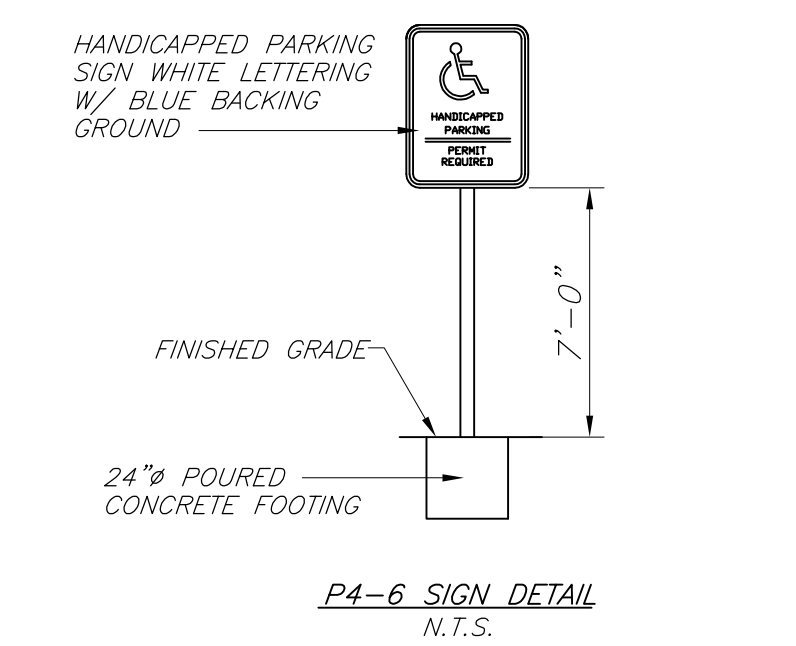
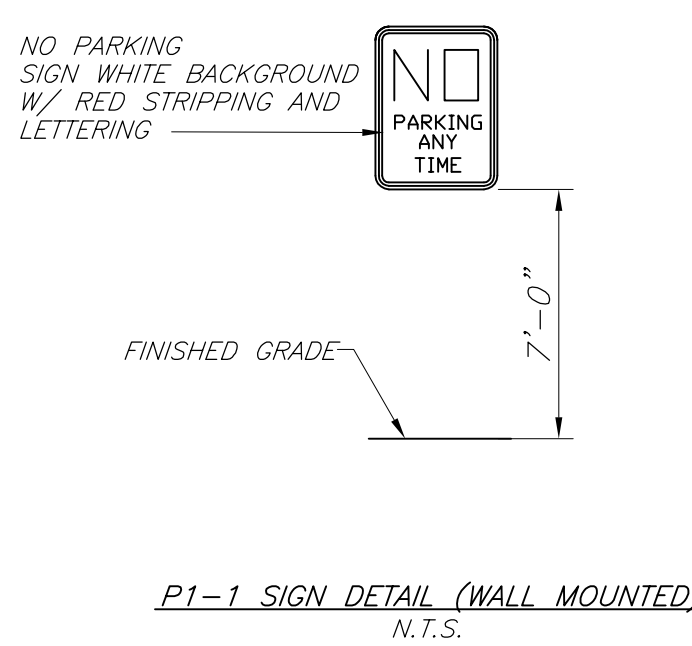

REVISIONS			
REV.	DATE	BY	DESCRIPTION

<b>ENGINEER</b>	<b>TALCOTT ENGINEERING DESIGN PLLC</b>		
	1 GARDNERTOWN ROAD NEWBURGH, NY 12550 (845)-569-8400 (FAX)(845)-569-4583 TALCOTTDESIGN12@GMAIL.COM		
<b>DETAILS</b>			
<b>COMMERCIAL SITE PLAN</b>			
<b>O'DONNELL</b>			
<b>RT 52, SBL: 47-1-48</b>			
<b>TOWN OF NEWBURGH, ORANGE COUNTY, NY</b>			
DATE	SCALE	JOB NUMBER	SHEET NUMBER
12/20/21	AS NOTED	20003-MDL	3 OF 3